

NOVA

Emergency Lighting Inverter

6, 8, 10, 15, 17KW

Installation and Operation Manual

Beghelli USA
3250 Corporate Way
Miramar, FL. 33025 USA
TF: (800) 726-4316

Service: (800-726-4316)

Due to continuous product improvement, this document is subject to change without prior notice

Notice of Rights

This document contains proprietary and confidential information of Manufacturer.

No part of this manual may be reproduced, copied, translated or transmitted, in any form or by any means, without the prior written permission of the manufacturer.

In consideration of the receipt of this document, the recipient agrees not to copy any of its contents, nor to disclose them to or allow them to be used by any person not currently company employee or an employee of the recipient having a need to know, without the express written consent of the company, and further agrees to surrender this document to company when the reason for its receipt has terminated.

Notice of Liability

Information provided in this manual is intended to be accurate and reliable. However, manufacturer assumes no responsibility for its use, nor for any infringement of rights of third parties which may result from its use. THIS DOCUMENT IS PROVIDED "AS IS" AND ANY EXPRESS OR IMPLIED WARRANTIES, INCLUDING, BUT NOT LIMITED TO, THE IMPLIED WARRANTIES OF MERCHANTABILITY AND FITNESS FOR A PARTICULAR PURPOSE ARE DISCLAIMED. IN NO EVENT SHALL ABOVE COMPANY BE LIABLE FOR ANY DIRECT, INDIRECT, INCIDENTAL, SPECIAL, EXEMPLARY, OR CONSEQUENTIAL DAMAGES (INCLUDING, BUT NOT LIMITED TO, PROCUREMENT OF SUBSTITUTE GOODS OR SERVICES; LOSS OF USE, DATA, OR PROFITS; OR BUSINESS INTERRUPTION) HOWEVER CAUSED AND ON ANY THEORY OF LIABILITY, WHETHER IN CONTRACT, STRICT LIABILITY, OR TORT (INCLUDING NEGLIGENCE OR OTHERWISE) ARISING IN ANY WAY OUT OF THE USE OF THIS DOCUMENT, EVEN IF ADVISED OF THE POSSIBILITY OF SUCH DAMAGE.

Trademarks

All trademarks and registered trademarks are the property of their respective owners.

Emergency Lighting Inverter Installation and Operation Manual
Document No.:110-MAN-BG, Rev. X1
February 20, 2019

Table of Contents

TABLE OF CONTENTS	3
INTRODUCTION	5
SECTION 1. SAFETY	7
SECTION 2. OVERVIEW	10
2.1 PRODUCT DESCRIPTION	10
2.2 PRODUCT MAIN FEATURES	12
SECTION 3. HARDWARE OVERVIEW	14
3.1 KEY COMPONENTS	14
3.2 TYPICAL FUNCTIONAL DESCRIPTION	18
3.3 THEORY OF OPERATION	20
SECTION 4. INSTALLATION	22
4.1 DELIVERY SPACE REQUIREMENTS	22
4.2 SITE CONSIDERATIONS	26
4.3 DELIVERY AND HANDLING	30
SECTION 5. OPERATION	41
5.1 STARTING THE UNIT FOR THE FIRST TIME	41
5.2 TURNING OFF THE UNIT	43
5.3 STARTING THE UNIT AFTER A PLANNED SHUTDOWN	43
SECTION 6. MAINTENANCE	44
6.1 SAFETY PRECAUTIONS	44
6.2 PREVENTATIVE MAINTENANCE	45
6.3 FRU REPLACEMENT	49
6.4 CALLING FOR SERVICE	52
6.5 CUSTOMER SERVICE AND SUPPORT	52
SECTION 7. TROUBLESHOOTING	54
7.1 TROUBLESHOOTING GUIDE AND SYSTEM ALARMS	54
7.2 USING THE LCD DISPLAY PANEL	55
7.3 DEFAULT SCREEN 1	56
7.4 DEFAULT SCREEN 2	57
7.5 DEFAULT SCREEN 3	57
OPTIONS	58
8.1 INTERNAL MANUAL BYPASS SWITCH (MAKE BEFORE BREAK)	58
8.2 EXTERNAL WRAP-AROUND MANUAL BYPASS SWITCH (SAME INPUT AND OUTPUT VOLTAGE)	58
8.3 AUDIO ALARMS WITH SILENCE SWITCH	61
8.4 REMOTE STATUS PANEL	61
8.5 TRANSIENT VOLTAGE SURGE-SUPPRESSOR (TVSS)	62
8.6 OFFLINE INVERTER OPERATION	62
8.7 NORMALLY ON/OFF OUTPUT AUX. CIRCUIT BREAKERS	62

8.8 MAIN INPUT CB STANDARD/HIGHER KAIC	62
8.9 MAIN OUTPUT CB STANDARD/HIGHER KAIC.....	62
8.10 HIGHER KAIC NORMALLY ON/OFF AUX OUTPUT CIRCUIT BREAKER.....	62
8.11 POWER FLOW MIMIC	62
8.12 GLOBAL MONITORING SYSTEMS (GMS)	63
8.13 SIMPLE NETWORK MANAGEMENT PROTOCOL.....	67
8.14 SEISMIC MOUNTING BRACKET	69
8.15 BATTERY STRING MONITORING (WIRELESS).	69
8.16 BATTERY (INDIVIDUAL) MONITORING (WIRELESS)	69
8.17 FORM "C" N/O CONTACTS FOR ALARMS.....	69
8.18 DRY CONTACT, N/O OR N/C CONTACT WITH ISOLATED COMMON.....	69
8.19 BATTERY THERMAL RUNAWAY CONTROL.....	70
8.20 BATTERY BREAKER ALARM	70
INDEX	80

Introduction

Congratulations on selecting one of the fine products from the leader in power-protection technology. Our wide product offering includes Uninterruptible Power Systems (UPS), power conditioners, automatic voltage regulators, and specialty transformers (e.g., computer-grade, medical-grade). Since 1972, the manufacturer has shipped many of these fine products to discerning customers around the world for use on sensitive equipment and critical applications.







The **NOVA** Lighting Inverter is a self-contained unit that provides backup power for fluorescent and incandescent lighting sources such as overhead fixtures and exit signs. If a brownout or power outage occurs, the inverter provides 90 minutes of lighting power to ensure a safe building evacuation. On line pulse-width modulation (PWM) handles the switchover from utility power to battery power automatically, without interruption or manual intervention. Convection cooling allows the inverter to operate virtually silently.

Scope and Audience

This guide is intended to be used as a reference for users responsible for installing, operating, and maintaining this equipment.

Safety and Warnings

This guide uses the following symbols to draw your attention to certain information :

	Note	Notes emphasize or supplement important points of the main text.
	Tip	Tips provide helpful information, guidelines, or suggestions for performing tasks more effectively.
	Caution	Cautions indicate that failure to take a specified action could result in damage to the hardware.
	DANGER	The Danger symbol warns users of possible injury or death if instructions are not followed.
	Hazardous voltage	Hazardous voltage inside. Only authorized personnel may service this equipment.
	Electrostatic sensitive	Components are Electrostatic Discharge Susceptible (ESDS) Use a grounded ESD wrist strap.

Warranty Registration and Warranty Certificate Request

Web: www.beghelliusa.com/downloads/forms/nova-warranty-request.pdf



NOVA
6, 8, 10, 15 & 17KW

Service

If you require assistance, fill out a Service Report Form at <http://www.beghelliusa.com/downloads/forms/nova-service-request.pdf>, or call our toll free hot line (800-726-4316). Please have the unit's SERIAL NO. from the Start-Up **label** located on the top right front door for speed assistance.

Section 1. Safety



DANGER: This Equipment is intended to be permanently connected. Only factory-trained or authorized personnel should attempt to install or repair the unit or its battery system. Improper installation has proven to be the single most significant cause of start-up problems. High AC and DC electrical voltages are present throughout the unit(s) and incorrect installation or servicing could result in electrocution, fire, explosion, or equipment failure.



DANGER: Read this manual in its entirety before performing the installation, start-up, operation, or maintenance of the UPS unit or battery systems. Failure to do so could result in electrocution, fire, explosion, or equipment failure.



DANGER: All power connections must be completed by a licensed electrician who is experienced in wiring this type of equipment. Wiring must be installed in accordance with all applicable national and local electrical codes. Improper wiring may cause damage to the equipment, injury or death of personnel. Verify that all high and low voltage input power circuits are de-energized and locked out before installing cables or making any electrical connections.



DANGER: Exercise extreme care when handling unit and batteries to avoid equipment damage or injury to personnel. Cabinets weigh several hundred pounds.



DANGER: Test lift and balance the cabinets before moving. Maintain minimum tilt from vertical at all times. The bottom structure will support the unit only if the forklift forks are completely underneath the unit.



DANGER: Observe all battery safety precautions during installation or service of the unit or batteries. Even with the battery circuit breaker in the off position, the danger of electrocution may still be present. The battery power to the unit must be locked and tagged "off" before performing any service or work on the unit. The battery manufacturer's safety information and material safety data sheet are located in a pocket attached to inside the front door of each unit. Failure to follow those instructions and the instruction listed above and elsewhere in this manual could result in an explosion, fire, equipment failure, or electrocution.



DANGER: All power to the unit must be locked and tagged "off" before performing any service or work on the unit. Failure to do so could result in electrocution.



DANGER: In case of fire involving electrical equipment, only carbon dioxide fire extinguishers, or those approved for use on electrical equipment, should be used. Use of water on fires involving live high voltage electrical circuits could present an electrocution hazard.



DANGER: Extreme caution is required when performing maintenance. Lethal voltages exist within the equipment during operation. Observe all warnings and cautions in this manual. Failure to comply may result in serious injury or death. Obtain qualified service for this equipment as instructed.



DANGER: Be constantly aware that the unit system contains high DC as well as AC voltages. With input power off and the battery disconnected, high voltage at the filter capacitors and power circuits should discharge within 30 seconds. However, power circuit failures can occur, so you should always assume that high voltage might still exist after shutdown. Verify that power is off using AC and DC voltmeters before making contact.



DANGER: Some components within the cabinets are not connected to chassis ground. Any contact between floating circuits and the chassis is a lethal shock hazard.



DANGER: Internal battery strapping must be verified by the customer prior to moving this unit.

This unit contains non-spillable batteries. Keep the unit upright. Do not stack. Do not tip. Always follow the battery manufacturer's safety information, the inside of the door of your unit, to prevent an accident that could result in injury or death.



DANGER: Lead-acid batteries contain hazardous materials. Batteries must be handled, transported, and recycled or discarded in accordance with federal, state, and local regulations. Because lead is a toxic substance, lead-acid batteries should be recycled rather than discarded.

Do not dispose of batteries in a fire, the batteries may explode.

Do not open or mutilate the batteries. Released electrolytes are harmful to the skin and eyes and may be toxic.

A battery can have a high short circuit current and present a risk of electrical shock. The following precautions should be observed when working on batteries:

1. **Remove watches, rings, or other metal objects.**
2. **Use tools with insulated handles.**
3. **Wear rubber gloves and boots.**
4. **Do not lay tools or metal parts on top of batteries.**
5. **Disconnect charging source prior to connecting or disconnecting battery terminals.**
6. **Determine whether battery is inadvertently grounded. If so, remove the source of the ground. Contact with any part of a grounded battery can result in electrical shock. The likelihood of such shock will be reduced if such grounds are removed during installation and maintenance.**
7. **Lead-acid batteries can present a risk of fire because they generate hydrogen gas. The following procedures should be followed:**
 - Do not smoke when near batteries.
 - Do not cause flame or spark in battery area.
8. **Discharge static electricity from your body before touching batteries by first touching a grounded surface.**

Section 2. Overview

2.1 Product Description

The **NOVA** Lighting Inverter is manufactured to provide critical power for lighting during a power outage. The Lighting Inverter meets or exceeds the life safety codes of UL924 and UL1778. These codes were established to allow emergency lighting inverters to provide critical power to the lighting circuits during a power failure.

If input power to the inverter is lost during a power outage, the system draws clean sine wave power automatically from its internal battery supply without any interruption. Power is provided for 90 minutes, sufficient time for safe and orderly evacuation from the facility.

An optional output transformer allows multiple output voltages as well as input voltages that are different from output voltages. The internal valve regulated lead-acid (VRLA), maintenance-free batteries provide 90 minutes of backup power. When input power is restored, the Lighting Inverter resumes normal operation automatically and begins recharging the batteries immediately.

An internal bypass circuit maintains power to the load in case an internal unit failure occurs. Comprehensive monitoring capabilities include a Liquid Crystal Display (LCD) panel and five dry relay contacts for remote monitoring.

NOVA Lighting Inverters are on-line single phase PWM inverters. The systems support power ratings of 6, 8, 10, 15, 17KW.

The **NOVA** Lighting Inverters comply with UL1778, UL924, UL924A, and CSA107.1 standard. They are available with input or output voltages of 120, 208, 240, 277 or 480 VAC, single phase. This information is shown on the nameplate located on the inside front door of the unit.

Table 2-1. Lighting Inverter Cabinet dimensions

Rating	Cabinet Size (Including Battery) (W x H x D in Inches)	Cabinet Type
6KW, 8KW	39 x 68 x 18	See Figure 4-1
10KW, 15KW, 17KW	51 x 70 x 30.5	See Figure 4-2

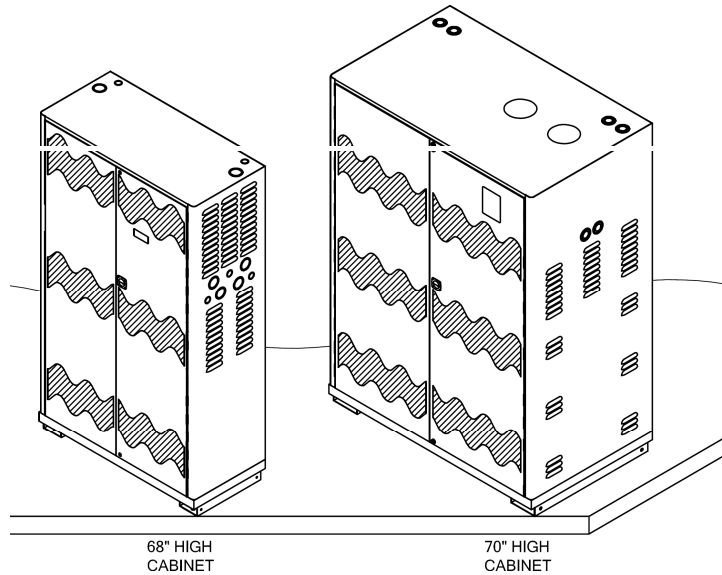

Figure 2-1. NOVA Lighting Inverter Cabinets)

Table 2-2. Standard Series Cabinet Dimensions and Types for Zone 4 (With Seismic Brackets)

Rating	Cabinet Size (Including Battery) (W x H x D in Inches)	Cabinet Type
6KW, 8KW	46.75 x 68 x 18 (Including brackets)	See Figure 4-3
10KW, 15KW, 17KW	58.75 x 70 x 30.5 (Including brackets)	See Figure 4-4

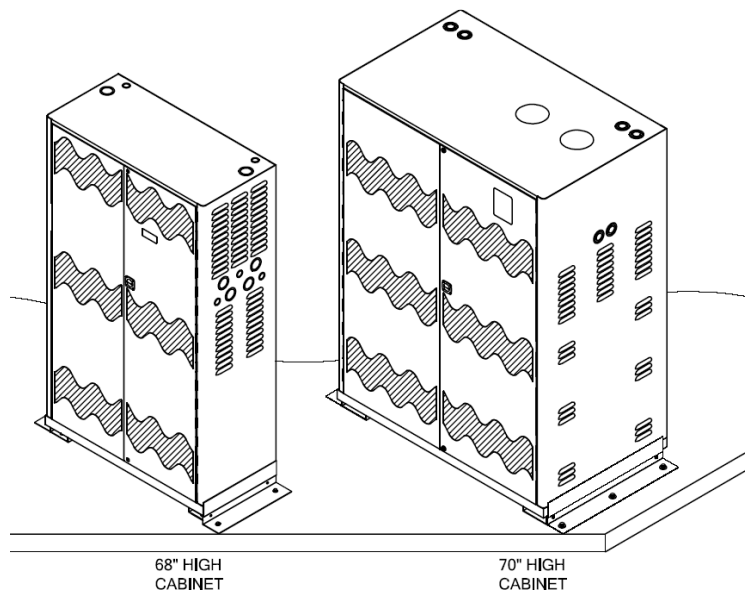

Figure 2-2 NOVA Lighting Inverter Cabinets for Zone 4 (With Seismic Brackets)

2.2 Product Main Features

Item	Components	Function
1	Input Contactor K1	The input contactor is multifunctional. First, it provides connections for the input power to the unit. Secondly, the contactor disconnects the input line when an outage occurs so that there is no back feeding of power into the power line. Finally, the contactor allows for automatic unit operation upon a complete discharge of the batteries. No operator intervention is required when power to the unit is restored after a complete battery discharge.
2	Battery Charger	The battery charger maintains the batteries at full charge. After a battery discharge, the charger will automatically recharge the batteries upon restoration of input power. This circuit is on the Power Board.
3	Power Board Assembly with IGBTs	The Power Board is bolted onto the IGBT (Insulated Gate Bipolar Transistor) blocks that are mounted on a heat sink. The complete Heat Sink Assembly with IGBTs and Power Board is replaceable as a single part. This FRU (Field Replaceable Assembly) converts all the power, i.e. input AC power converted to DC bus, battery power boosted to DC bus, and finally DC bus power converted to output AC power using PWM technology for a smooth AC sine wave. In case of a catastrophic failure, the complete Heat Sink Assembly is easily replaceable using only a screwdriver. The Power Board also contains the housekeeping power supplies and drivers for the IGBTs. The entire assembly provides the landing place for all internal input, output, DC cables and metering devices for control and monitoring of the unit input and output currents.
4	Control Board	The microprocessor with unit specific firmware and control circuitry is located on the Control Board. The Control Board is mounted on the cabinet door and communicates with the Power Board (A2) via a ribbon cable. It monitors the input and output voltages and generates the command to close or open the input contactor and to sense and change the status of the bypass static switch. The Control Board sends data to the LCD panel located on the door where actual status and parameters are displayed. It additionally provides optional AS400, RS232, and RS485 output capabilities and supports various communication including SNMP options.
5	Output Static Switch	This SCR solid-state switch connects the output of the inverter (UPS) to the load. It is connected on the primary side of the optional output isolation transformer. This switch shuts off in case of a problem or failure within the unit and transfers the load directly to the utility input via the bypass static switch. It maintains its status opposite to that of bypass switch.

Item	Components	Function
6	LCD Display Panel	The LCD (Liquid Crystal Display) panel provides all the input, output, battery metering and alarm data, and UPS status for customer use on a constantly scrolling set of 2 default screens with continuous update.
7	Optional Output Isolation Transformer	The output isolation transformer provides isolation between the inverter and protected output. The power to the primary of this transformer is received from the unit and is transformed to required output voltage levels. It will also add another screen to the main menu.
8	Optional Maintenance Bypass Switch	The MBS (Maintenance Bypass Switch) removes the critical load from the backup power and provides utility input directly to the load in case of a unit malfunction or during system maintenance.
9	Battery Bank	The battery bank consists of sealed, maintenance-free batteries. The batteries provide emergency power during power outages. The battery bank includes a breaker for over current protection and DC disconnect.

Section 3. Hardware Overview

3.1 Key Components

Figure 3-1 shows the key system components and Table 3-1 describes them.

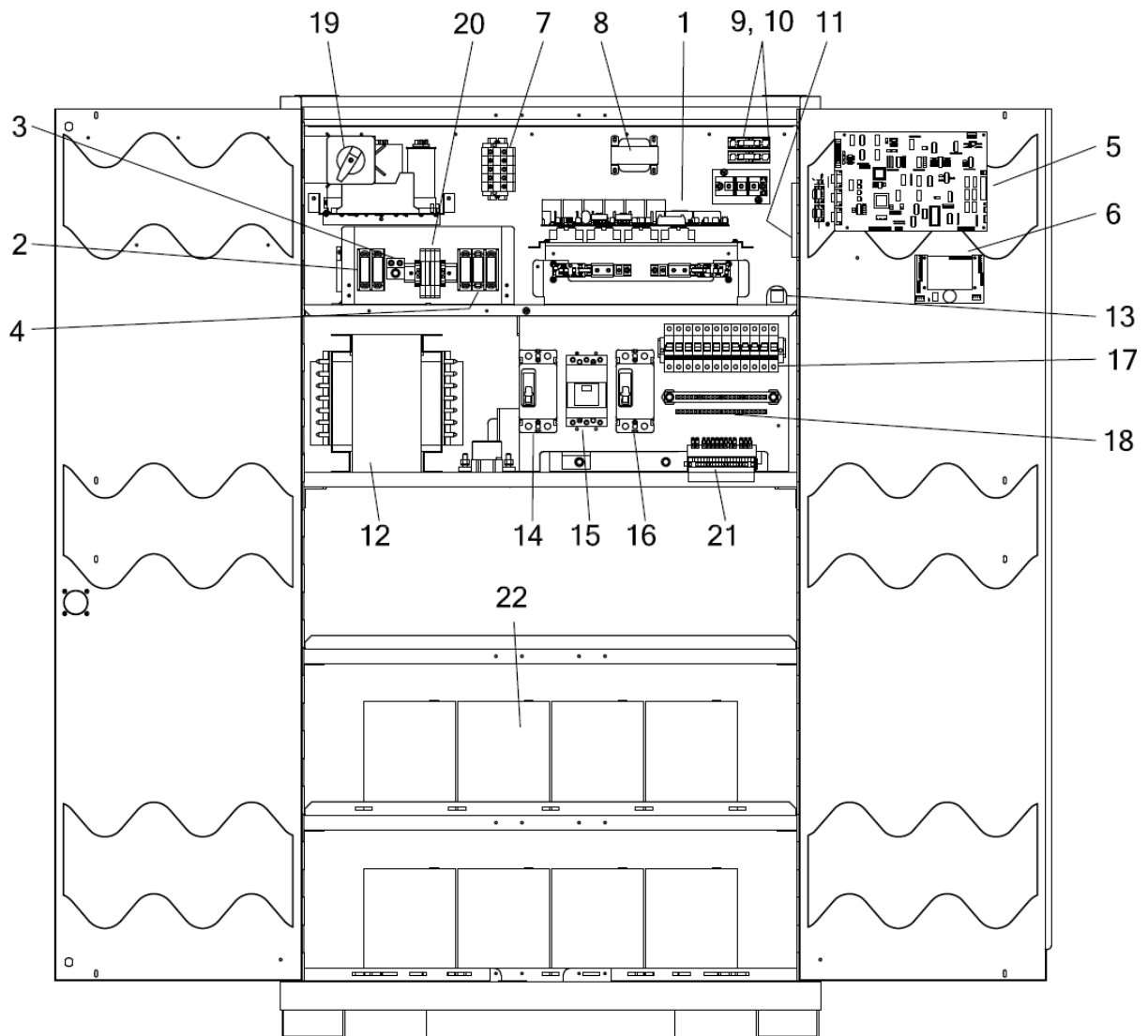

Figure 3-1. Key Components (6kW, 8kW) typical

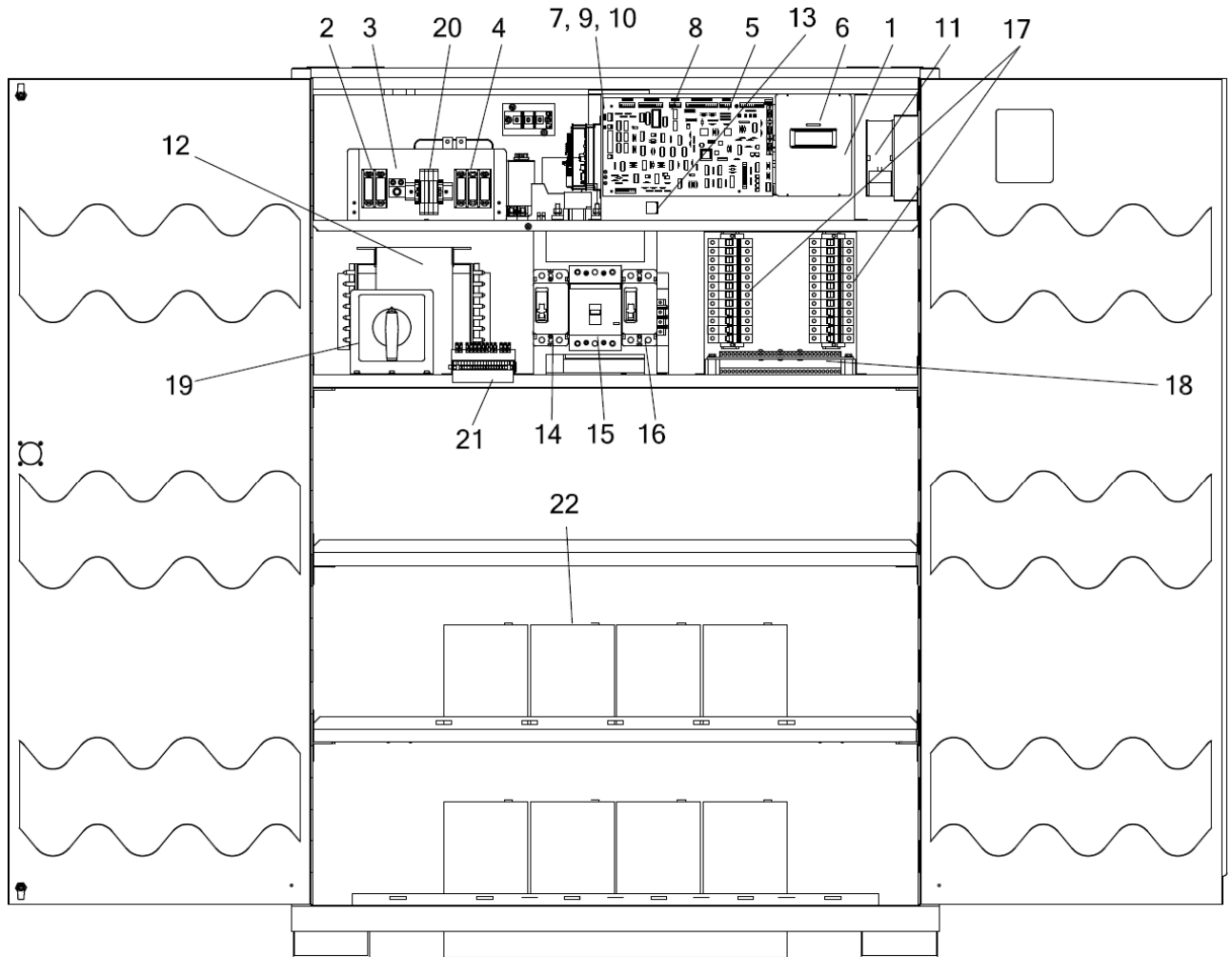

Figure 3-2. Key Components for all other units (typical)

Callout	Component Name	Description
1	Heatsink FRU Assembly for 6KW, 8KW Behind hinged panel for all others	Power board (A1) The power board is bolted onto the Insulated Gate Bipolar Transistor (IGBT) blocks mounted on a heat sink. The complete heat sink assembly with IGBTs and power board is a single Field Replaceable Unit (FRU) that converts all the power: Input AC power converted to DC bus. Battery power boosted to DC bus. DC power converted to output AC power using PWM technology for a smooth AC sine wave. If a catastrophic failure occurs, the heat sink assembly can be replaced using only a screwdriver. The power board also has the housekeeping power supplies and drivers for the IGBTs. The entire assembly provides the landing place for all internal input, output, DC cables, and metering devices for controlling and monitoring the unit input and output currents.
		Bypass static switch (PB2) Bypass static switch is closed only upon inverter fault or output overload condition.
		Inverter static switch (PB1) The SCR solid-state switch connects the output of the inverter (UPS) to the load. It is connected on the primary side of the optional output isolation transformer. If problem or failure occurs in the unit, this switch shuts off and transfers the load directly to the utility input via the bypass static switch. It maintains its status opposite to that of the bypass switch.
2	Input 2-Pole terminal block (TB1)	Customer Input power connection. See 4.3.6 (page 32)
3	Ground Lug (Input and Output)	2-barrel lug for Input and Output Ground. See 4.3.6 (page 32)
4	Output 2-Pole / 3-pole terminal block (TB1)	Customer output connection. See 4.3.6 (page 32)
5	Control board (A2)	The microprocessor with unit specific firmware and control circuitry is located on the Control Board. The Control Board is mounted on the cabinet door and communicates with the Power Board (A2) via a ribbon cable. It monitors the input and output voltages and generates the command to close or open the input contactor and to sense and change the status of the bypass static switch. The Control Board sends data to the LCD panel located on the door where actual status and parameters are displayed. It additionally provides optional AS400, RS232, and RS485 output capabilities and supports various communication including SNMP options.
6	LCD display panel	Provides continuously updated input, output, battery metering and alarm data, and UPS status for customer use on a constantly scrolling set of 2 default screens.

Callout	Component Name	Description
7	Terminal block for removing heat sink assembly (TB4) 6KW, 8KW Behind hinged panel for all others	5-position terminal block (TB4). This terminal block provides quick and easy removal of power assembly.
8	Fan transformer, Control power transformer (T2) 6KW, 8KW Behind hinged panel for all others	Provides 120 VAC to the fans, with taps to match unit output voltages.
9	Control transformer fuse (F1), 6KW, 8KW Behind hinged panel for all others	Control transformer over current protection.
10	Fan fuse (F2) 6KW, 8KW Behind hinged panel for all others	Fan overcurrent protection.
11	Fan(s) and under heatsink	Provides system cooling.
12	Output isolation transformer T1, as required	Provides isolation between the inverter and protected output. Power to the primary of this transformer is received from the unit and is transformed to the appropriate output voltage levels. It also adds a screen to the main menu.
13	Inverter test switch (S2)	Push-button switch for testing the Lighting Inverter and its batteries for proper operation. When the unit is operating, pressing and holding in switch SW-2 transfers the system to battery operation. The system continues to run on batteries until the switch is released. When the switch is released, the system returns to normal operation so long as input power is present.
14	(Main Input breaker (CB3)	Provides input overcurrent protection.
15	Battery breaker (CB1)	Provides overcurrent protection for battery bank.
16	Main output breaker (CB2)	Provides output overcurrent protection.
17	(Optional) Output Auxiliary Breakers	Normally ON/OFF Output Auxiliary Breakers (6) (Optional).
18	(Optional) Gnd/Neu terminals	Gnd/Neu terminals for optional auxiliary output breakers (optional).
19	Bypass switch	Optional: Removes the critical load from the backup power and provides utility input directly to the load in case the unit malfunctions or during system maintenance (optional). Refer to 3.2.5 page 7 for detail.
20	(Optional) TVSS (Transient Voltage Surge Suppressor)	This option is a no-fuse, fail-safe surge suppressor featuring a fail-safe self-protected design, visual indicator.
21	(Optional) Interfaces terminal blocks for customer connection (General location)	Options customer connections i.e. form "C" contact terminals, RS232.....each terminal is marked accordingly for proper connection refer to each option for connection details in each cabinet size.

Callout	Component Name	Description
22	Maintenance free lead acid battery(s)	Batteries are sealed, maintenance-free, self-regulated lead acid construction, to provide emergency power during power outages. Other battery options are available upon request.

3.2 Typical Functional Description

Figure 3-3 shows the major blocks within the system and the sections following the figure describe them.

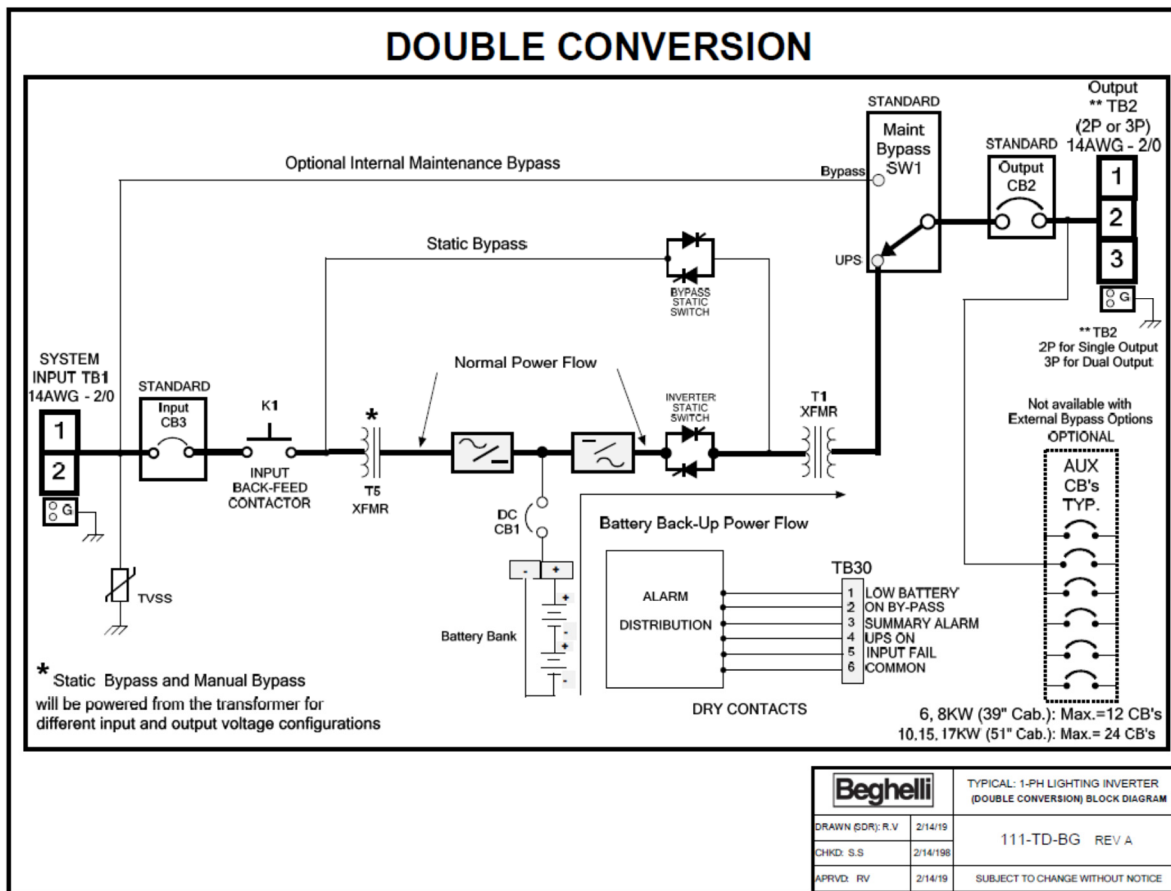

Figure 3-3. Major System Blocks (Double Conversion Mode)

3.2.1 Inverter

The inverter accepts the available DC power from the rectifier or the battery banks and converts it to AC power for the critical load.

3.2.2 Battery Charger

The battery charger converts AC power into regulated DC power to recharge and maintain the charge on the battery bank. The charger is fully automatic, with a current-limiting feature that prevents battery damage in case of a charger malfunction.

The charger is sized so that the batteries are maintained at full charge, even when the input voltage is at the low line limit for indefinite periods of time.

3.2.3 Battery

The battery bank consists of 12, 16, or 20 12-Volt batteries. These batteries provide the reserve energy to sustain the load when suitable AC input power is not present. The batteries are sealed, maintenance-free, valve-regulated lead acid (VRLA) construction.

3.2.4 Output Transformer

An output isolation transformer shall be utilized to provide specified multiple output voltages, while providing the following functions:

- It provides excellent common mode and normal mode noise isolation of the load from the input or inverter power.
- It provides voltage transformation and tight regulation of the output voltage, while the system operates from its internal inverter.
- It can be used to provide a different voltage from the input source voltage.

3.2.5 Internal Maintenance Bypass Switch, MBS Switch

Internal Manual Maintenance Bypass Switch is a (3) position “UPS”, “SBS” and “BYPASS” rotary switch, when set to “BYPASS” provides power directly from UPS main input feed to the load which ensures continuous power to critical load without interruption.



Caution: Do not leave the switch in the SBS position; otherwise, a loss of power to the critical load will occur when the inverter is de-energized.

3.2.6 Efficiency Optimizer Function: (OFF Line Inverter Mode)

When input power is available, the batteries are charged and AC output from the inverter supports the critical load via the inverter static switch. This is normal mode, during which the inverter static switch is closed, and the bypass static switch is opened. The bypass static switch is closed only during inverter faults or manual operation, in which case the critical load is supported by output power from the bypass static switch.

This is normal operation for true-double convention UPS. However, higher efficiency UPS operation can be achieved to reduce electricity costs by operating the unit as an “off-line inverter.” This scenario reverses the normal operating mode. Normally, the bypass static switch is closed as long as the input voltage and input frequency are within $\pm 10\%$ of the normal input voltage range and ± 3 Hz of the normal input frequency range, and the inverter static switch is opened. In off-line inverter mode, the inverter static switch is closed only if input power fails or when and out-of-voltage and frequency condition exists.

By eliminating the requirement for an output voltage regulation of $\pm 10\%$ (voltage window range) or $\pm 15\%$ (selectable) voltage window range:

- **System efficiency increases by 2% to 4% depending on the model**
- **Total power loss is reduced.**
- **The output AC voltage in the mode of operation follows proportionally to the input line voltage.**

3.3 Theory of Operation

The following section describes the system's theory of operation.

3.3.1 Standby Mode Normal Mode

After power is applied to the system, the system enters standby mode and performs a self-test. During this period, the start subroutine checks for input voltage, and proper operation of the inverter and bypass SCRs. After the self-test completes successfully, the system enters normal mode.

During normal mode:

1. **Input contactor receives a closing signal that connects input power to the DC supply transformer.**
2. **The DC rectifier supplies the battery charger, control board, and the DC/AC inverter circuit.**
3. **The battery charger is activated, allowing the batteries to be charged continuously.**
4. **The on-line DC/AC inverter converts the DC voltage to a PWM waveform. This waveform is filtered and reconstructed to a desired AC output.**

3.3.2 Response to Input Power Failure

If the system controller senses a change in input frequency greater than ± 3 Hz or an out-of-range input voltage, it:

- **Considers the event as an input failure and opens the input contactor immediately, isolating the unit from the facility.**
- **Turns off the charger and makes the battery bank a DC supply source to the inverter circuit, maintaining an uninterrupted AC supply to the protected load.**
- **Issues a UPS ALARM message on the LCD display panel.**

When the facility power returns, stabilizes, and is in phase with the backup power, the system controller closes the input contactor and the system returns to normal mode. If the battery voltage drops below 16% of its nominal value and the facility power remains off, the system enters alert mode.

3.3.3 UPS Alert

The system controller issues an ALERT message on the LCD display panel if any of the following conditions occurs:

- **Internal failure**
- **System overheats**
- **Battery bank under-voltage**

During an alert:

- **The system stops its backup operation.**
- **The inverter SCRs are switched OFF.**
- **Bypass SCRs are switched ON.**
- **A summary alarm 5V signal is sent to the hardwired interface.**

The system remains in this mode until power is cycled or the system is repaired.

3.3.4 UPS Alarm

The system controller issues a **UPS ALARM** message on the LCD display panel if any of the following conditions occurs:

- **Input power failure**
- **Output overload**

When the system is in alarm mode, inverter IGBs remain on and an alarm signal may be sent to the signal interface. The system resets itself when the problem no longer exists.

3.3.5 Output Loads

The system is designed to power any fluorescent or incandescent HID lighting. However, certain types of loads exhibit an excessive inrush current when first turned on or at other times during operation.

As a result, the capacity of the system might need to be greater than the capacity that is estimated based on requirements shown on the system's nameplate. If you have questions about powering unusual loads from your system, contact your dealer or the factory.

Section 4. Installation

4.1 Delivery Space Requirements

The following figures show the dimensions of the system cabinets as well as key components used for cable access and mounting.

Verify that the delivery area, the destination, and the path between them meet the standard delivery clearance and weight requirements of the system.

The delivery area must provide enough space and floor strength to support the packaged equipment cartons for the system. Doorways and hallways must provide enough clearance to move the equipment safely from the delivery area to the destination. Permanent obstructions such as pillars or narrow doorways can cause equipment damage. If necessary, plan for the removal of walls or doors.

Verify that all floors, stairs, and elevators you use when moving the system to its destination can support the weight and size of the equipment. Failure to do so could damage the equipment or your site.

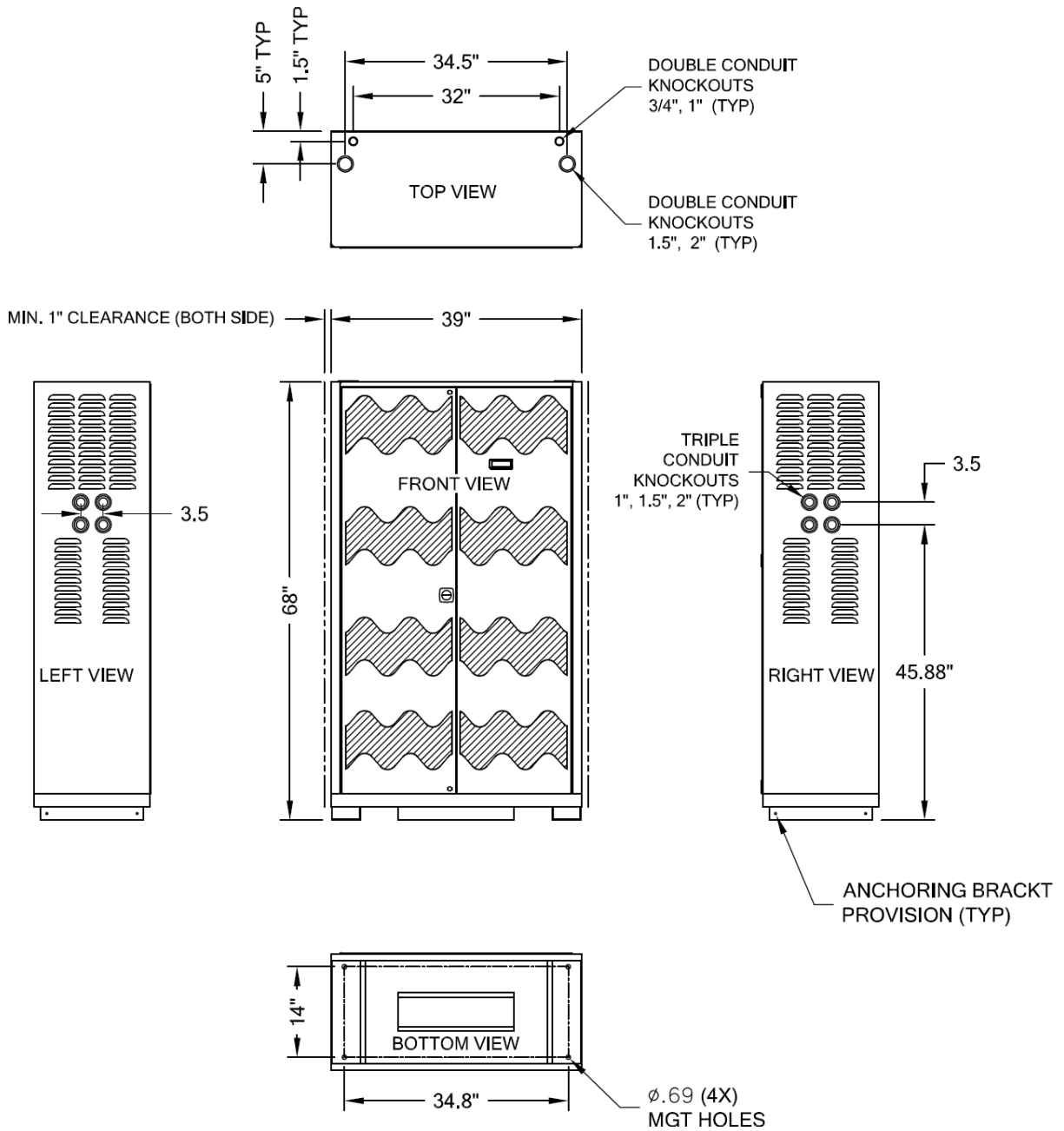

Figure 4-1. 6KW, 8KW Cabinet Mounting

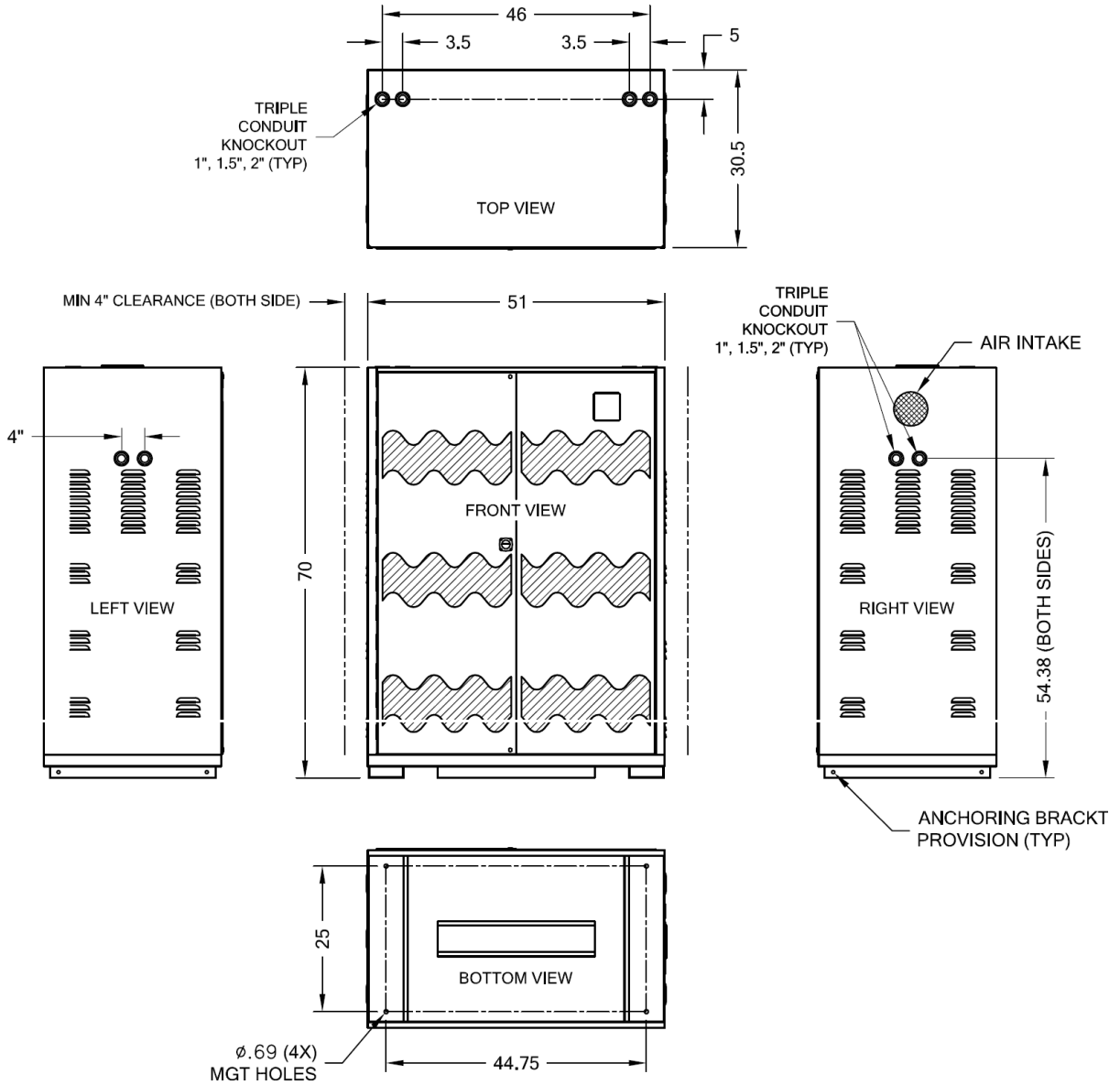

Figure 4-2. 10KW, 15KW, 17KW Cabinet Mounting

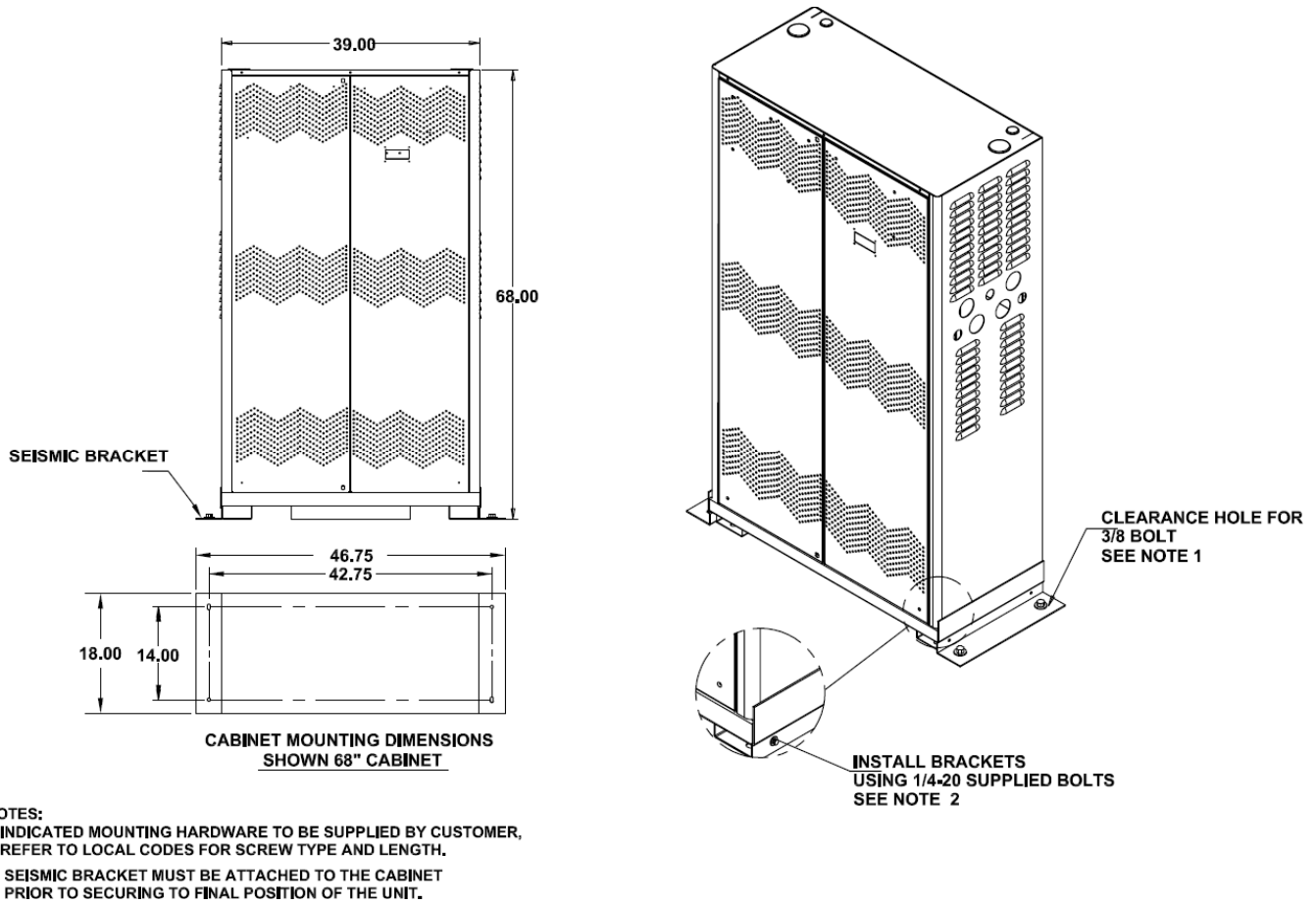

Figure 4-3. 6KW, 8KW Cabinet Mounting (with Optional Zone 4 Seismic Brackets)

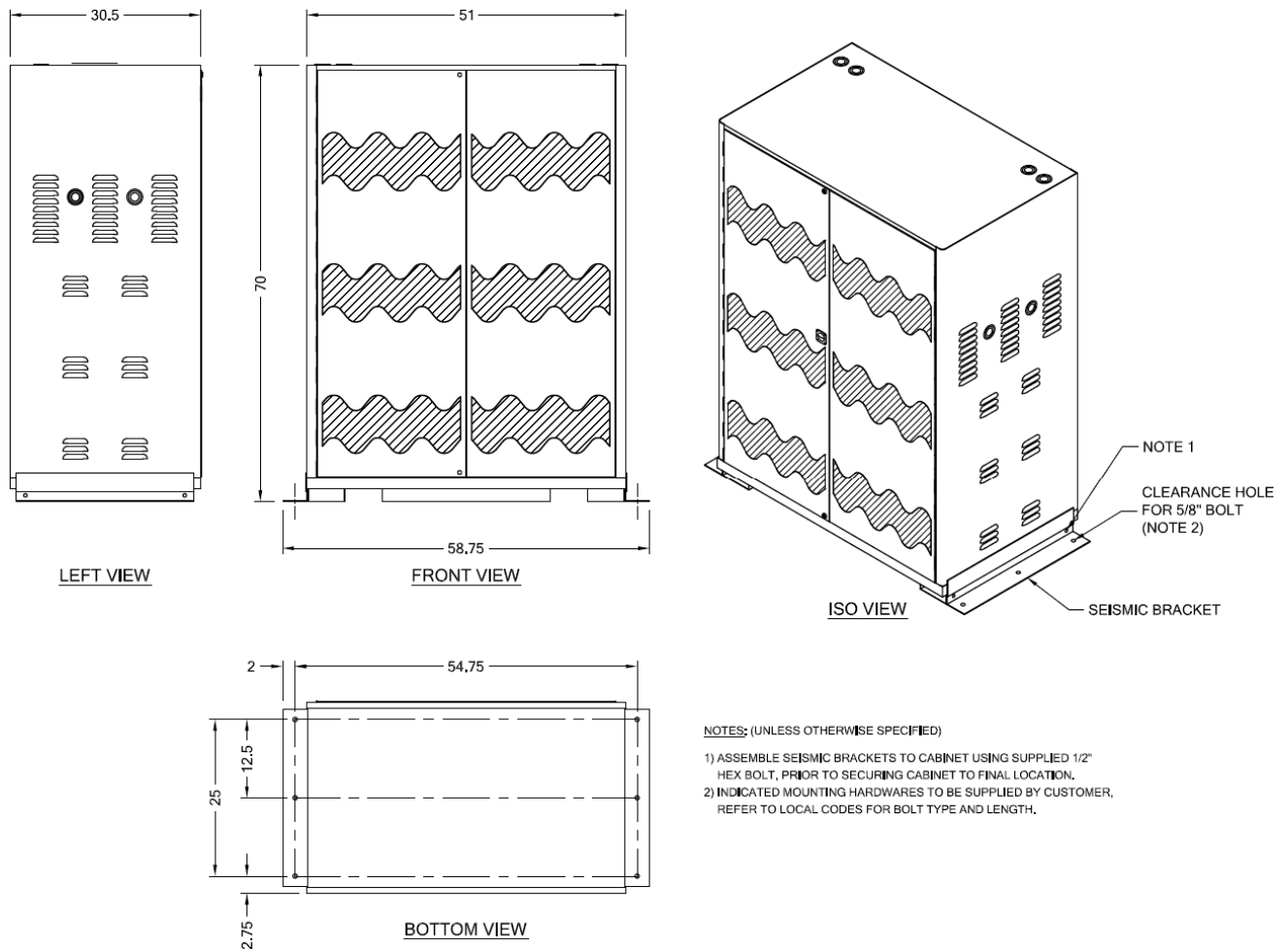

Figure 4-4. 10KW, 15KW, 17KW Cabinet Mounting (with Optional Zone 4 Seismic Brackets)



Note: Do not remove any knockouts that will not be used

4.2 Site Considerations

Planning the proper location and layout of the system prior to installing it is essential for successful operation. To ensure normal operation and to avoid unnecessary maintenance, plan your site configuration and prepare your site before installation, refer to Table 4-1, for facility recommendation.

The system is designed for indoor installation and meets NEMA specifications for operating temperature, humidity, and utility voltage. The system enclosures are rugged and corrosion resistant.

The system is less than 6 square feet. All servicing is performed through the front of the unit; therefore, leave sufficient room in the front of the unit for service access.

The following precautions will help you plan an acceptable operating environment for the system:

- **Select a flat location that is clean, with no dust or exposure to direct sunlight or vibrations. The location should provide a sturdy, level surface that can support the system. Avoid locations with inclined floors.**
- **The location should not be prone to variations in temperature and humidity or be close to strong magnetic fields or a device that generates electric noise.**
- **The unit should not place the system next to, on top of, or below any device that generates heat or will block the free flow of air through the system's ventilation slots**
- **The Lighting Inverter cabinets provide cable and conduit openings on the top and sides of the cabinet. Be sure these areas are not blocked and can be easily accessed to expedite installation.**
- **Electrical equipment generates heat. Ambient air temperature might not be adequate to cool equipment to acceptable operating temperatures without adequate circulation. Ensure that the room in which the system will operate has adequate air circulation.**



Caution: Always follow proper ESD-prevention procedures to avoid damage to equipment. Damage from static discharge can cause immediate or intermittent equipment failure.



Caution: For sites with **Generator** and **Automatic Transfer Switch (ATS)** in conjunction with the unit, make sure the ATS has an open transition with minimum 20 milli-seconds transfer time (gap) in **both directions**

4.2.1 Recommended Facility Protective Device Ratings, BTU/HR, & Floor Loading.

Table 4-1

Rating KW	Input Volt.	Output Volt.	Unit Input Current		Facility Recommended Input Circuit Breaker Current (AMP)	Batt . Volt	Max. Batt. Disch AMP	*BTU/HR Double Conversion (Typical)	*BTU/HR Fast Transfer (Typical)	Unit Weight (including Batteries) lbs. (Approx.)	Floor Loading LB/SQFT	Cabinet Dimensions W x H x D Inches
			Normal	Max								
6.0	120	120	63	79	90	144	56	1965	Reduce 100 BTU/HR per KW	1284	329	39 x 68 x 18
	208	208	36	45	60	144	56	1965		1284	329	
	240	240	31	39	50	144	56	1965		1284	329	
	277	277	27	34	40	144	56	1965		1284	329	
8.0	120	120	83	104	150	192	56	2600		1464	375	
	208	208	48	60	70	192	56	2600		1464	375	
	240	240	42	52	60	192	56	2600		1464	375	
	277	277	36	45	50	192	56	2600		1464	375	
10.0	120	120	116	145	200	192	70	3057		2870	332	51 x 70 x 30.5
	208	208	67	84	100	192	70	3057		2870	332	
	240	240	58	73	90	192	70	3057		2870	332	
	277	277	50	63	80	192	70	3057		2870	332	
15.0	120	120	165	206	275	240	111	5000	4512	522		
	208	208	95	119	150	240	111	5000	4512	522		
	240	240	83	104	130	240	111	5000	4512	522		
	277	277	71	89	120	240	111	5000	4512	522		
17.0	120	120	185	232	300	240	126	5400	4512	522		
	208	208	107	134	170	240	126	5400	4512	522		

Rating KW	Input Volt.	Output Volt.	Unit Input Current		Facility Recommended Input Circuit Breaker Current (AMP)	Batt · Volt	Max. Batt. Disch AMP	*BTU/HR Double Conversion (Typical)	*BTU/HR Fast Transfer (Typical)	Unit Weight (including Batteries) lbs. (Approx.)	Floor Loading LB/SQFT	Cabinet Dimensions W x H x D Inches
			Normal	Max								
	240	240	94	118	150	240	126	5400		4512	522	
	277	277	80	100	125	240	126	5400		4512	522	

*For Different Input / Output voltage units, add 100 BTU/HR per KW for Transformer

Note: For all wire sizes consult local codes and NEC based on unit current requirements



Caution: Warning: The External input circuit breaker protecting the system must be a "MOTOR START", Delayed trip type.

4.2.2 Operating Environment

The location you choose for installation should confirm to the following conditions.

Table 4-2. Inverter Environmental Specifications

Inverter Environment	Description
Operating Temperature:	0° to 40°C (0 to 104°F) Battery compartment to be kept at battery operating temperature
Altitude:	1,829 meters (6,000 feet) de-rate 10% for each additional 305 meters (1,000 feet) up to 2,744 meters (9,000 feet)
Relative humidity:	0% to 95% (non-condensing)
Audible Noise:	57 dBA, typical

Table 4-3. Battery Environmental Specifications

Battery Environment	Description
Ambient temperature:	20° to 25°C (68° to 77 °F)
Relative humidity:	0% to 95% (non-condensing)
Operating altitude:	1,829 meters (6,000 feet) de-rate 10% for each additional 305 meters (1,000 feet) up to 2,744 meters (9,000 feet)



Caution: Operating batteries outside of the specifications will shorten battery life significantly.

4.2.3 Floor Load Ratings

The floor space at the installation site must be strong enough to support the combined weight of the Lighting Inverter unit and all its batteries. To ensure adequate load-bearing capacity, plan for the maximum configuration.

4.3 Delivery and Handling

4.3.1 Inspecting the Shipment

The equipment included in your shipment consists of one Lighting Inverter cabinet. Batteries will typically ship separately unless specified otherwise. The contents are covered with protective wrapping and packaged in heavy-duty cardboard. Each item is labeled with the component name for easy identification.

When the equipment arrives, count the number of items delivered to ensure that you have the complete shipment. Inspect all protective wrapping or crates and any boxes for signs of rough handling or damage, such as punctures and crushed sides, preferably without moving the equipment. If the shipping container or equipment itself shows evidence of damage, record the damage on the receiving document before signing for receipt of the equipment. Damage claims should be filed directly with the carrier.

Thoroughly inspect each battery for any signs of damage. If there is any damage, reject the shipment and notify the manufacturer at (800-726-4316). If possible, photograph the damage for future reference. As you unpack the pallet or container, check each battery box for damage on all sides, the top and bottom. If there is any sign of damage, photograph the damage if possible, and call (800-726-4316).

4.3.2 Offloading the System

Because the system is designed for pad mounting, it is not accompanied by casters. At the user's discretion, a forklift can be used to off load the unit from the shipping pallet. Always be sure that the load capacity of the forklift is sufficient to support the weight of the unit and its batteries.



DANGER: Exercise extreme care when handling the cabinets to avoid equipment damage or injury to personnel. Each cabinet weighs several hundred pounds. Test lift and balance the cabinets before moving. Maintain minimum tilt from vertical at all times. The bottom structure will support the unit only if the forklift forks are completely underneath the unit.

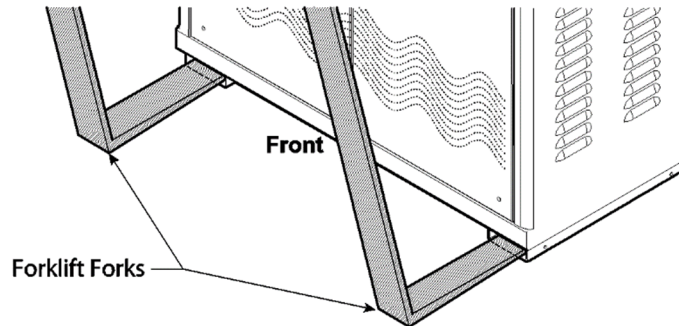

4.3.3 Climatization

Units that are shipped or stored at extreme temperatures require time to adjust to operating temperatures before startup. If the unit arrives in hot or cold weather, do not unpack it until it has been allowed to reach room temperature (one to two hours). Immediately exposing the unit to warm temperature can cause condensation to occur, which could damage the electronics. If you notice any condensation, allow the unit to stand unattended for one to two hours, and then unpack it.

4.3.4 Unpacking the Equipment

After checking the cartons for signs of damage, perform the following steps to unpack the equipment:

1. **Open all cartons.**
2. **Compare the items received to the packing list. If an item is missing or damaged, contact your place of purchase.**
3. **Remove all packing materials, envelopes, and boxes from the cartons. Please keep all packing materials and cartons in case you need to transport or ship the unit.**

In addition to the contents supplied with the unit, the user must supply a fork lift to perform the installation.



Note: After unpacking and **before turn-on:**

use plastic cover provided in the pouch on the front door to cover the unit during installation and while waiting for turn on, to prevent dust, construction debris and any other foreign object entering the unit.

Accumulation of dust and debris on all electronic will cause damage which will not be covered by warranty.

4.3.5 Cabling and Mounting

The top and sides of the unit have conduit openings for running cables.

1. **Before placing the unit onto the mounting bolts where it will be installed, remove the predrilled conduit knockouts on the top and sides of the cabinet (see section 4.1).**



Note: The predrilled conduit knockouts are positioned to prevent airflow disruptions that could cause the unit to overheat. If site restrictions prevent routing the conduit to the locations of the conduit knockouts, do not drill holes in the cabinet without first consulting the factory at (800-726-4316). Our engineers will assist you in locating the conduit to maintain unit reliability.

2. **Determine which knockouts will be used to route cables into and out of the unit. Remove only the conduit knockouts that are to be used.**
3. **Measure the locations for the conduits on the conduit knockouts.**
4. **Punch holes in the conduit knockouts.**
5. **Anchor the cabinet to the mounting pad at the four mounting locations (see Figure 4-1 to Figure 4-4)**
6. **Anchor the conduits to the conduit knockouts.**



Note: Do not remove any knockouts that will not be used.

4.3.6 Electrical Connections

The following sections describe how to perform the electrical connections. In these sections, "TB" refers to terminal block. Before making electrical connections, observe the following:



DANGER: Verify that all customer-supplied wiring is de-energized before performing any electrical work. Failure to do so could result in electrocution, injury, or damage to equipment.



DANGER: Even when the unit is off, there are potentially dangerous voltages within the power wave unit due to the batteries. Exercise extreme care when working within the power wave enclosure to avoid the possibility of electrocution, injury or damage to the equipment.

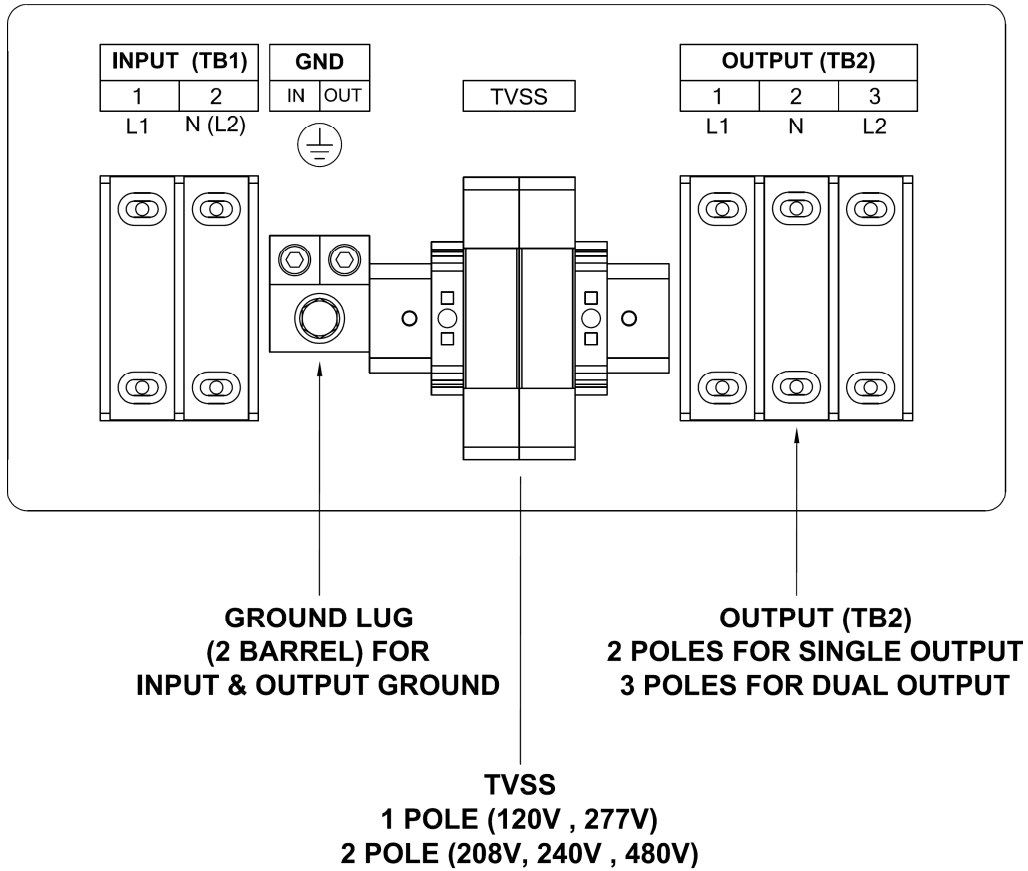

Figure 4-5 Input / Output Terminal Block Section Typical Arrangements

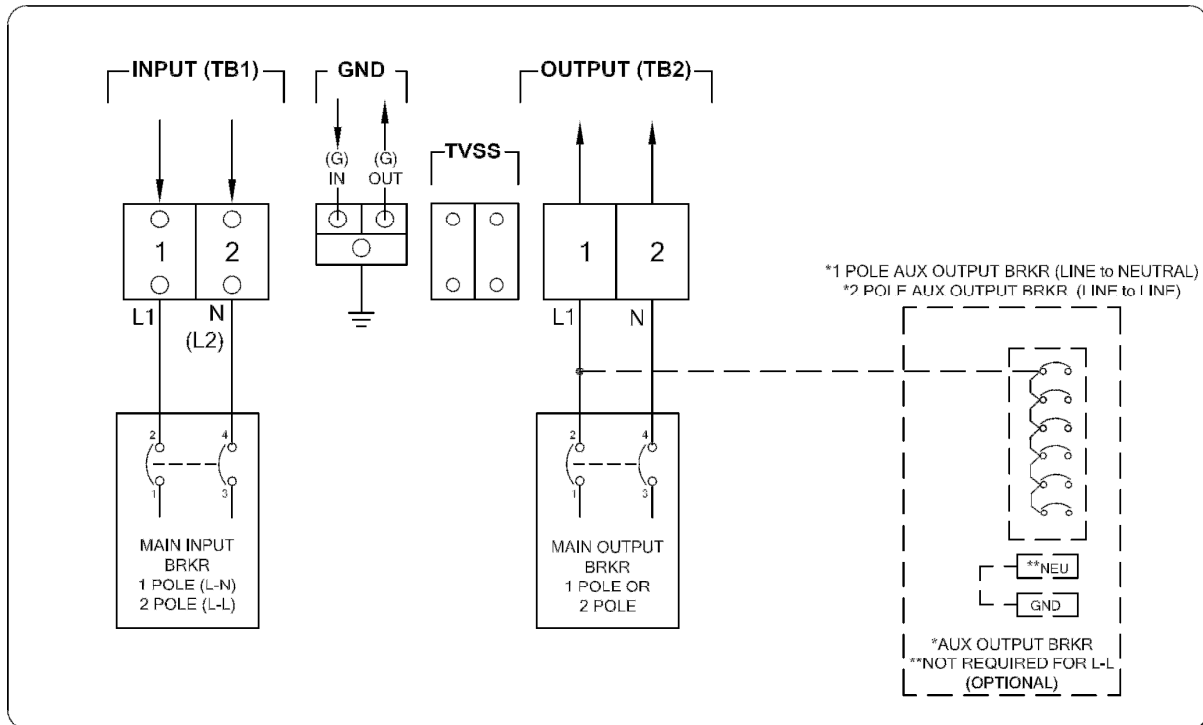

Figure 4-6 Single Output Voltage Connection with Optional Main Input/Output and Auxiliary Breakers (Typical)

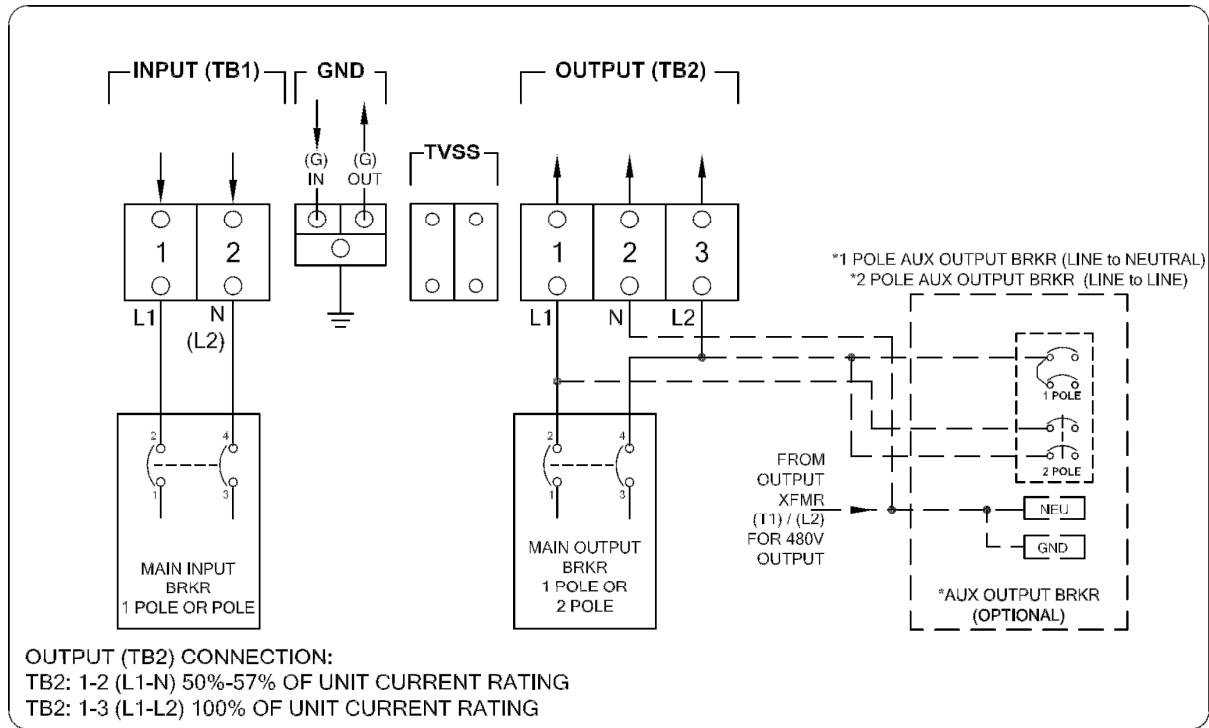

Figure 4-7 Dual Output Voltage Connection with Optional Main Input/Output and Auxiliary Breakers (Typical)

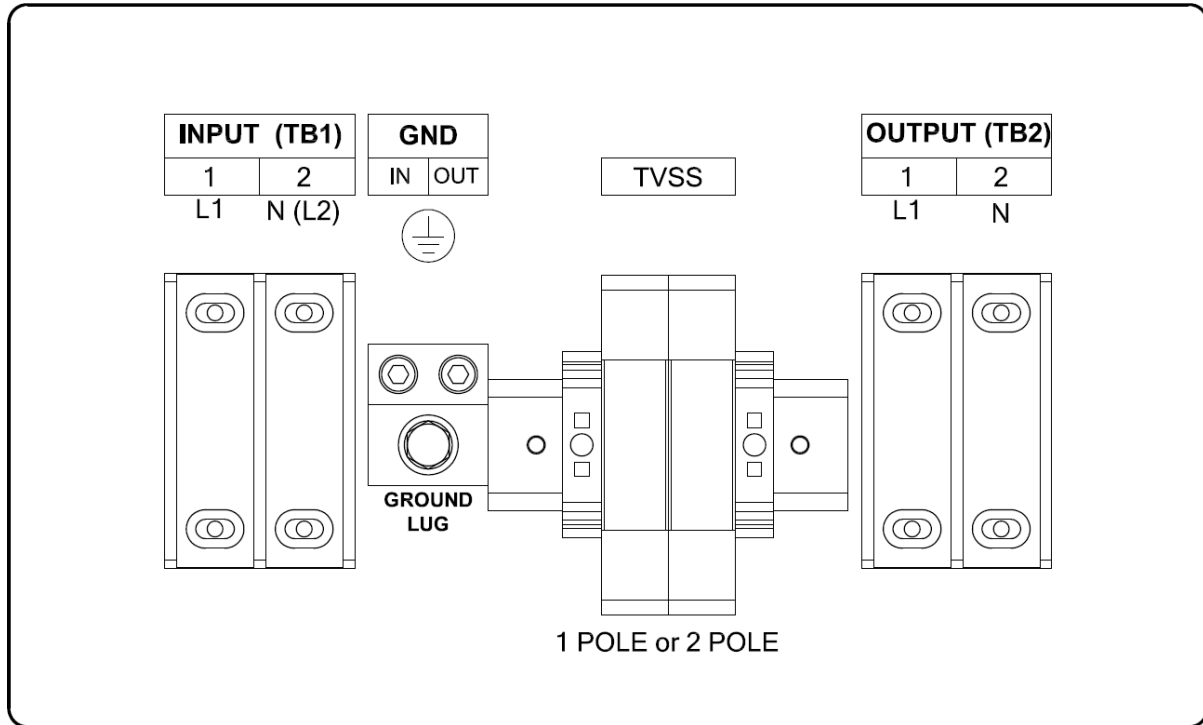
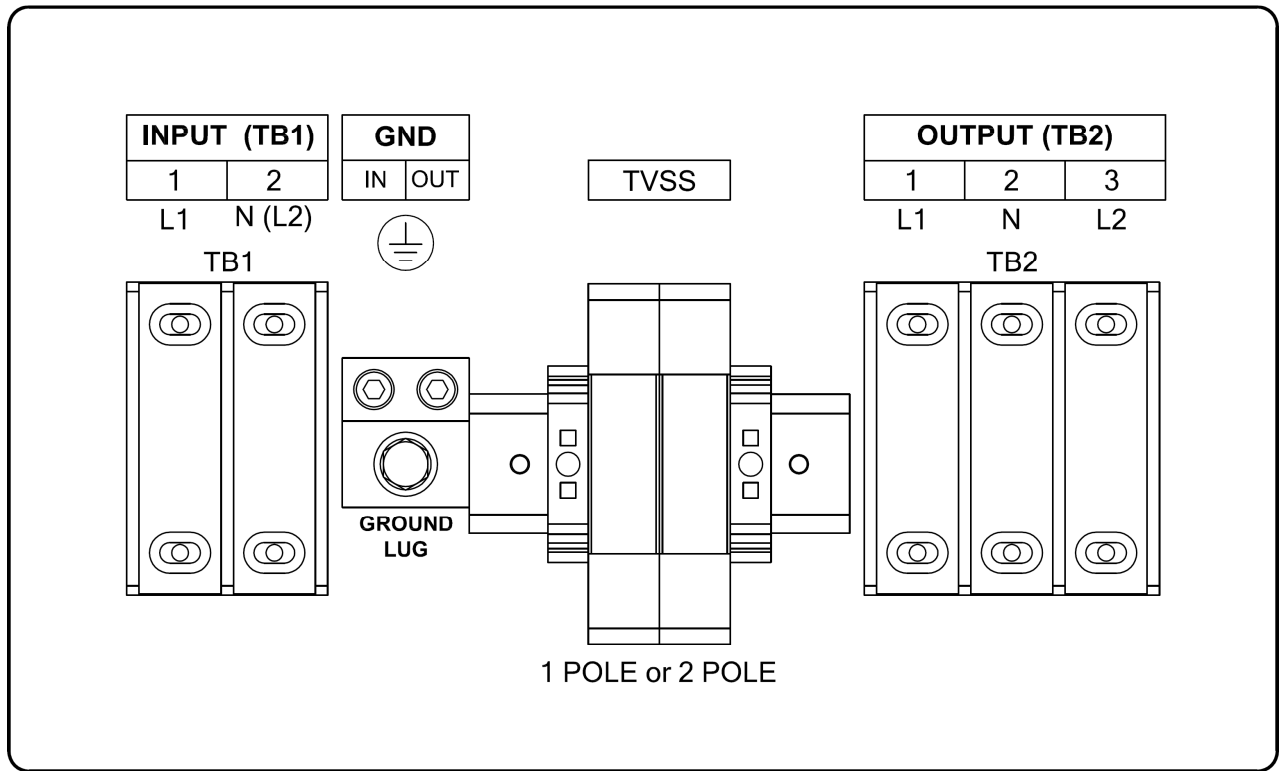

Figure 4-8 Input and Output Connection Single Output Voltage (120V, 277V)

Table 4-4 Input and Output Connection Single Output Voltage

Input Connection			
Volt	TB1		Ground Lug
	1	2	Input
120	L1	N	GND (IN)
208	L1	L2	GND (IN)
240	L1	L2	GND (IN)
277	L1	N	GND (IN)
480	L1	L2	GND (IN)

Output Connection			
Volt	TB2		Ground Lug
	1	2	Output
120	L1	N	GND (OUT)
208	L1	L2	GND (OUT)
240	L1	L2	GND (OUT)
277	L1	N	GND (OUT)



4-9 Input and Output Connection Dual Output Voltage

Table 4-5 Input and Output Connection Dual Output Voltage

Input Connection			
Volt	TB1		Ground Lug
	1	2	Input
120V	L1	N	GND (IN)
208V	L1	L2	GND (IN)
240V	L1	L2	GND (IN)
277V	L1	N	GND (IN)
480V	L1	L2	GND (IN)

Output Connection				
Volt	TB2			Ground Lug
	1	2	3	Output
120V	L1	N		GND (OUT)
240V	L1		L2	
120V	L1	N		GND (OUT)
277V		N	L2	
277V	L1	N		GND (OUT)
480V	L1		L2	

4.3.6.1 Battery Connections

There are various battery configurations based on battery run time and battery bus voltages. For reference purposes, see APPENDIX B - Battery Connections. For information about specific battery connections, refer to the battery connection diagram for each sales order.



Caution: Ensure that the DWG NO of the system matches the DWG NO on the nameplate. See the sample nameplate in Figure 4-10.

NAME	
<u>UPS CABINET</u>	
SERIAL NO.:	_____
MODEL NO.:	_____
RATING:	_____ P.F.: _____
FREQUENCY:	_____
INPUT VOLTAGE:	_____
INPUT CURRENT:	_____
OUTPUT VOLTAGE:	_____
OUTPUT CURRENT:	_____
BATTERY VOLTS:	_____
BATTERY CURRENT:	_____
BACK-UP TIME:	_____
BATTERY QTY:	_____
BATTERY P/N:	_____
MFG DATE:	_____
DWG NO:	_____
 US LISTED 183550	
EMERGENCY LIGHTING AND POWER EQUIPMENT UL924/-A, CSA-C22.2.107.3-05 / UL1778 Ed.4.	
<small>ALL VALUES ARE NOMINAL</small>	

Figure 4-10. Sample Nameplate

4.3.7 Optional Remote Signaling Connections

The **NOVA** Lighting Inverter includes optional dry contacts relay for remote signaling.

4.3.7.1 Form "C" N/O Contacts for Alarms

Refer to Figure 8-1 for connection details

4.3.7.2 Dry Contact, N/O or N/C Contact with Isolated Common

Refer to Figure 8-1 for connection details

4.3.8 Storing the System

If you will not be using the system as soon as you receive it, keep it in its original packing material and store it in an indoor environment that meets the following conditions.

Specification	Description
Ambient temperature:	-20° to 70°C (-4° to 158°F)
Relative humidity:	0% to 95% (non-condensing)



Note: After unpacking and **before turn-on:**

Use plastic cover provided in the pouch on the front door to cover the unit during installation and while waiting for turn on, to prevent dust, construction debris and any other foreign object entering the unit.

Accumulation of dust and debris on all electronics will cause damage which will not be covered by warranty.

4.3.9 Recharging Batteries During Storage

If the unit will be stored for three months or longer, visually inspect, and charge the batteries for 24 hours at regular, three-month intervals.

To recharge the batteries, use the following procedure:

1. **If the unit is stored in its original packaging, unpack it using the unpacking procedures section 4.3.4.**
2. **If the unit is not connected to a source of power, connect it to an appropriate power source.**
3. **Recharge the batteries:**
 - a. Unlock and open front doors.
 - b. Set AC input power source to ON.
 - c. Close the input circuit breaker and wait 1 minute.
 - d. When **UPS Normal** appears on the LCD display panel, close the battery circuit breaker.
 - e. The unit recharges the batteries automatically. The LCD display panel shows the battery voltage and charging current.
 - f. Allow the unit to run for 24 hours to fully charge the batteries.
 - g. When the batteries reach partial charge, the battery charging current will be under 1 Amp on the LCD display panel.
 - h. Open the battery breaker.
 - i. Turn off input power to the unit.
 - j. Close and lock the front door.

Section 5. Operation

5.1 Starting the Unit for the First Time

Initial start-up of the unit **must be performed by factory certified personnel** or an authorized representative. To request start-up:

1. Download the Request for Turn-On form from www.beghelliusa.com/downloads/forms/turn-on-request.pdf
2. Either complete the form online or fax a printed copy to Beghelli USA at (954-442-6677).

The following procedure describes the initial start-up. Do not start up the unit without the assistance of factory-trained and authorized personal; otherwise, you might damage the unit and void the unit warranty.

1. Verify that there is no power coming to the unit by checking the facility, main input battery, and output circuit breaker(s), they should all be in OFF position.
2. Verify the batteries are installed and torqued in accordance to the battery connection diagram provided with the unit inside the front door pocket.
3. Confirm that all cable connections are secured firmly.



Caution: If anything, unusual occurs during the start-up procedure, turn off the input circuit breaker immediately and call our toll free number at (800-726-4316).

4. Apply input power to the unit.

- a. Input circuit breaker remains open.
- b. Verify that the voltage measured on the input circuit breaker is 120, 208, 240, 277 or 480 VAC and is the same as nameplate voltage rating. If the voltage is not the same as on the nameplate within +15% to -10% tolerance, call our toll free number at (800-726-4316) for technical assistance before proceeding.
- c. Verify that there are no voltages measured on the output terminal block.

5. Turn on the main input circuit breaker to turn on the system.

6. Wait one minute while the system performs internal diagnostic routines. During this time, confirm that you:

- a. Hear the sound of the contactor closing.
- b. See the fan(s) running.
- c. See the message **UPS NORMAL** on the LCD display panel.

Line 1	UPS NORMAL	@	XX KW
Line 2	INPUT OK	@	CHRG ON
Line 3	BATTERY OK	@	DC OK
Line 4	ON INVERTER	@	OUT OK

- d. The LCD display panel shows correct parameters (see Section 7.).
 - e. The output voltage is 120/208/240 or 277 VAC, according to the values on the nameplate.
- #### 7. Close the battery breaker in the UPS cabinet and in the battery cabinets if any.
- #### 8. The unit should be providing AC line power. If the unit is not operating in the normal mode, turn off the input circuit breaker and contact our toll free number (800-726-4316).
- #### 9. Recheck that the output voltage is 120/208/240 or 277 VAC.
- #### 10. Verify battery operation and the functionality of the inverter test switch:

- a. Press and hold the yellow Inverter Test push-button to operate the unit from its internal batteries and simulate a loss of input power. With the push-button in the hold position, the unit should be running on its internal batteries.
- b. Verify that the LCD display panel shows the following messages, where xx is the KW of this unit:

Line 1	UPS ALARM	@	XX KW
Line 2	INPUT BAD	@	CHRGR OFF
Line 3	BATTERY OK	@	DC OK
Line 4	ON INVERTER	@	OUT OK

- c. Release the yellow Inverter push-button and verify that the LCD display panel shows **INPUT BAD @ CHRGR OFF** as shown above.



Caution: Be sure to release the push-button after the test, so it does not deplete the batteries.

The unit is now fully functional and providing clean, sine wave power to the load, with battery back-up in case of an input power failure.

5.2 Turning Off the Unit

There may be times when you need to turn off the unit, such as for planned maintenance.

To turn off the unit, perform this procedure in the following order:

1. Turn off the output breakers.
2. Turn off the battery breaker.
3. Turn off the input breaker.

5.3 Starting the Unit After a Planned Shutdown

Use the following procedure to start the unit after a planned maintenance shutdown or after a power outage.

1. Apply input power.
2. With input power available, turn on the main input circuit breaker.
3. Wait until you hear the input contactor closing and fan running.
4. After the LCD display is lit and shows the messages in Section 7. , close the battery circuit breaker.
5. Verify that all parameters on the LCD display panel are appropriate (see Section 7.).
6. Close the output circuit breaker.
7. Turn on the auxiliary output circuit breakers.

Section 6. Maintenance

6.1 Safety Precautions

Observe the following safety precautions when performing maintenance on the unit.



DANGER: Read and understand this section thoroughly before performing any maintenance work on or around the UPS. Read the battery manufacturer's manual and material safety data sheets before working on or near the batteries. Only normal safety precautions are required when the UPS is operating with all cabinet doors closed. However, the UPS cabinets or Battery cabinets (if applies) must be kept free of standing puddles of water, excess moisture, or debris. **Debris can consist of excessive dust in and around the unit, as the cooling fans in the UPS will pull this dust into the unit.**



DANGER: Only factory trained, or authorized personnel should attempt to install or repair the UPS or its battery system. Improper installation has proven to be the single most significant cause of start-up problems. Service personnel should wear insulating shoes for isolation from direct contact with the floor (earth ground) and should make use of rubber mats when performing maintenance on any portion of the unit while it is under power. High AC and DC electrical voltages are present throughout the unit(s) and incorrect installation or servicing could result in electrocution, fire, explosion, or equipment failure.



DANGER: Special safety precautions and lockout tagout procedures are required for all operations involving the handling, installation, or maintenance of the UPS system and any associated batteries or battery cabinets (if applies). Failure to follow safety procedures could result in death, injury or damage to equipment.



DANGER: This equipment contains circuits that are energized with high voltages. Only test equipment designed for troubleshooting high voltages should be used, particularly for oscilloscopes and probes. Always check with an AC and DC voltmeter to ensure safety before initiating contact or using tools. even when the power is off, dangerously high potential voltages may exist at capacitor banks. Always observe battery precautions when operating near any batteries. Failure to observe these precautions could result in death or in injury or damage to equipment.



DANGER: Observe all battery safety precautions during installation or service of the UPS or batteries. Even with the battery circuit breaker in the off position, the danger of "off" before performing any service or work on the unit. The battery manufacturer's safety information and material safety data sheet are located in a pocket attached to the inside of left door of each UPS. Failure to follow those instructions and the instruction listed above and elsewhere in this manual could result in an explosion, fire, equipment failure, or electrocution.



DANGER: Be constantly aware that the UPS system contains high DC as well as AC voltages. With input power, off and the battery disconnected, high voltage at the filter capacitors and power circuits should discharge within 30 seconds. However, power circuit failures can occur, so you should always assume that high voltage might still exist after shutdown. Verify that power is off using AC and DC voltmeters before making contact.

6.2 Preventative Maintenance

UPS operator maintenance consists of the basic tasks in this section. Other maintenance functions require factory Certified Service personnel.

6.2.1 Maintaining an Operator's Log

Careful record-keeping ensures proper maintenance of the unit and assists in the correction of any abnormal conditions.

The operator's log should contain the following information:

- **Date of system start-up**
- **Dates that battery maintenance was performed**
- **Dates that input, output, and battery status readings were checked and the values displayed for these readings**
- **Dates and summaries of all communications with Service personnel**
- **A copy of Service Log Sheet is provided with each unit, the form 6002-2017-04 can also be requested by calling customer service support.**

6.2.2 Periodically Testing the UPS

The unit should be manually exercised on a periodic basis (for example, once every three months) to force the UPS unit to transfer to the battery and return to main power. This process activates self-diagnostic testing that can reveal conditions that require attention.

6.2.3 Maintaining the Batteries



DANGER: The battery circuit breaker operates at the rated battery voltages at all times. A tripped battery circuit breaker indicates a serious problem that may result in serious injury or damage to the equipment. Determine the cause and take appropriate action as necessary. For example, check for a short circuit in the battery. For guidance, call our toll free number at (800-726-4316).



DANGER: The battery electrolyte is a diluted sulfuric acid that is harmful to the skin and eyes. It is electrically conductive and corrosive. Wear full eye and hand protection along with protective clothing. If the electrolyte contacts the skin, wash it off immediately with water. If electrolyte contacts the eyes, flush thoroughly and immediately with water. Seek immediate medical attention. Spilled electrolyte should be washed down with a suitable acid neutralizing agent. One common practice is to use a solution of approximately one pound (450 grams) of bicarbonate of soda to approximately one gallon (4 liters) of water. The bicarbonate of soda solution should be applied to the spill until evidence of chemical reaction (foaming) has ceased. The resulting liquid should be flushed with water and the area dried.



DANGER: Do not dispose of a battery or batteries in a fire. The batteries may explode causing death or serious injury.



Caution: Do not substitute batteries from other manufacturers without the express approval of the manufacturer Customer Service personnel.



Caution: Lead-acid batteries contain hazardous materials and must be handled, transported, and recycled or scrapped in accordance with federal, state, and local regulations. Since lead is a toxic substance, lead-acid batteries should be recycled rather than scrapped.



Caution: A battery can present a risk of electrical short and high short circuit current. The following precautions should be observed when working on or around batteries:

1. **Remove watches, rings, or other metal objects.**
2. **Use tools with insulated handles.**
3. **Wear rubber gloves and boots.**
4. **Do not lay tools or metal parts on top of batteries.**
5. **Disconnect charging source prior to connecting or disconnecting battery terminals.**
6. **Determine whether battery is inadvertently grounded. if so, remove the source of the ground. Contact with any part of a grounded battery can result in electrical shock. The likelihood of such shock will be reduced if such grounds are removed during installation and maintenance.**
7. **Lead-acid batteries can present a risk of fire because they generate hydrogen gas. The following procedures should be followed:**
 - Do not smoke when near batteries.
 - Do not cause flame or spark in battery area.
8. **Discharge static electricity from your body before touching batteries by first touching a grounded surface.**



DANGER: Do not ground battery positive or negative.



Caution: Lead-acid batteries can present a risk of fire because they generate hydrogen gas. The following safety procedures must be followed:

Do not smoke when near batteries.

Do not cause flame or sparks in battery areas.

Discharge static electricity from your body before touching batteries by first touching a grounded metal surface.



Use of any non-Factory Tested/UL924 Certified batteries, including those with similar brand name and part number, will void the systems UL 924 Safety Certification Listing. Please call or e-mail Power Services for tested/certified replacement batteries.



Caution: The average annual ambient temperature of the batteries shall not exceed 77° F.



Caution: Battery Cell temperatures shall not exceed 92° F for more than 30 days annually.



Caution: Batteries are required to be installed and charged within 90 days of shipment.

6.2.4 Batteries

Although the individual batteries are sealed and require only minimal maintenance, they should be given a periodic inspection and electrical check. (Refer to schedule in log sheet provided inside front door pocket) to ensure years of trouble-free service. Tightness of battery terminal connections should be tested to recommended torque values. Battery Service Agreements are available by calling our toll free number at (800-726-4316).

For information about battery environment specifications, see Table 4-3. To qualify for battery-warranty replacement, you will need to show records of the battery maintenance history including battery numbers, battery voltages (individual cells), terminal torque measurements and dates of maintenance.

6.2.5 Power Connections

Check for corrosion and connection integrity. Visually inspect wiring for discolored or cracked insulation. Clean and/or re-torque as required.

All battery terminal connections must be tightened with the proper torque value set in accordance with the torque value on the Battery Connection Diagram provided with each system.

Use the correct torque tool to tighten the terminal bolts shown on the drawings shipped with each system. Use all hardware provided with the batteries.



Caution: Torque all connections in accordance with specified values provided. Failure to do so can create an unsafe condition or fire hazard.

6.2.6 Preventative maintenance programs are available through the Customer Service representative.

6.2.7 Battery Terminals

Check for discoloration, corrosion, and connection integrity. Clean and tighten as necessary.

To access battery terminals:

1. Remove the top strapping material located at the lower front of the battery shelf.
2. Pull the battery forward to access the battery connections.
3. Disconnect the cables connected to the battery, and then use a protective boot or electrical tape to insulate the cables to prevent accidental shorts.
4. Before replacing the battery connections, clean and re-torque the connection hardware.

6.3 FRU Replacement

Some components can be replaced by qualified factory-trained service personnel only. These components are referred to as Field Replaceable Units (FRUs).

Refer to Table 6-1 for ordering the replacement parts from the factory. Provide the unit's Serial No. from the Start-Up **label** located on the right front door.

North American users can call toll free: (800-726-4316). Replacement parts must be replaced by certified factory-trained service personnel only.



Electrostatic Sensitive: Circuit boards and IGBTs contain Electrostatic Discharge Susceptible (ESDS) components. Handle and package ESDS devices in accordance with JEDEC standard JESD625-A. Use a grounded ESD wrist strap when handling the devices and circuit boards. Always package components and circuit boards in static-dissipative plastic bags before transporting even if a device has failed. Failure to do so could result in further damage, complicating repair and failure analysis.

Table 6-1. Replacement Parts

Item	Description	Designator
1	Heat sink assembly	Power board (A1)
		Bypass static switch (PB2)
		Inverter static switch (PB1)
2	Power board	A1
3	Bypass static switch	PB1
4	Inverter static switch	PB2
5	Input/output/battery terminal block for customer use	TB1, TB2, TB3
6	Input choke	L1, L3
7	Output choke	L2
8	Dc choke	L4
9	The Frequency Noise Filter Capacitors for output Power	C1, C2, C3
10	Control board	A2

Item	Description	Designator
11	LCD display board	A5
12	Input contactor	K1
13	Terminal Block to remove heatsink assembly	TB4
14	Fan transformer	T3
15	Control power transformer	T2
16	Control transformer fuse	F1
17	Fan fuse	F2
18	Fan(s)	B1 thru B6
18	Optional output isolation transformer	T1
19	Input breaker	CB3
20	Battery breaker	CB1
21	Output breaker	CB2
22	Output distribution breaker	CB4 and up
23	Maintenance-free lead acid battery(s)	Battery 1 thru 20

6.3.1 Replacing the Control Board

The control board is located on the inside right door at the top and mounted at four corners with screws and washers. To replace the control board:

- 1. Disconnect and isolate all sources of power.**
- 2. Unplug P1 through P15, and then remove the control board.**
- 3. Install the new control board.**
- 4. Reconnect all plugs and connections maintaining them with their original orientations.**
- 5. Verify that all connectors are seated properly.**

6.3.2 Replacing a Heat Sink Assembly

To replace a heat sink assembly:

1. Disconnect and isolate all sources of power.
2. The heat sink assembly is located on the right side of the top electronic shelf inside the unit cabinet (see
3. Figure 6-1). Verify that all cables and connectors have labels and are identified as shown. This is important for reinstalling the assembly.
4. Disconnect connectors P7, P6, P4, and P1 from the printed circuit board A1, which is mounted horizontally on the big black heat sink.
5. Find the five power cables at TB4-1 through TB4-5 and affix the label ID to each cable. Then disconnect these five power cables using a flat-blade screw driver.
6. Loosen the three Phillips head screws at front holding heat sink bracket. Pull the complete assembly forward and up. Remove it from tray gently, making sure that no cables or wires are catching (see
7. Figure 6-1).
8. Install the new assembly in the reverse order. Note the rear bracket attached to the heat sink slides under the bracket secured on to the back panel. Slide the assembly back and reinstall the three Phillips screws.
9. Reinstall all the cables and connectors in the reverse order (see
10. Figure 6-1).
11. Verify connections prior to starting up the unit.

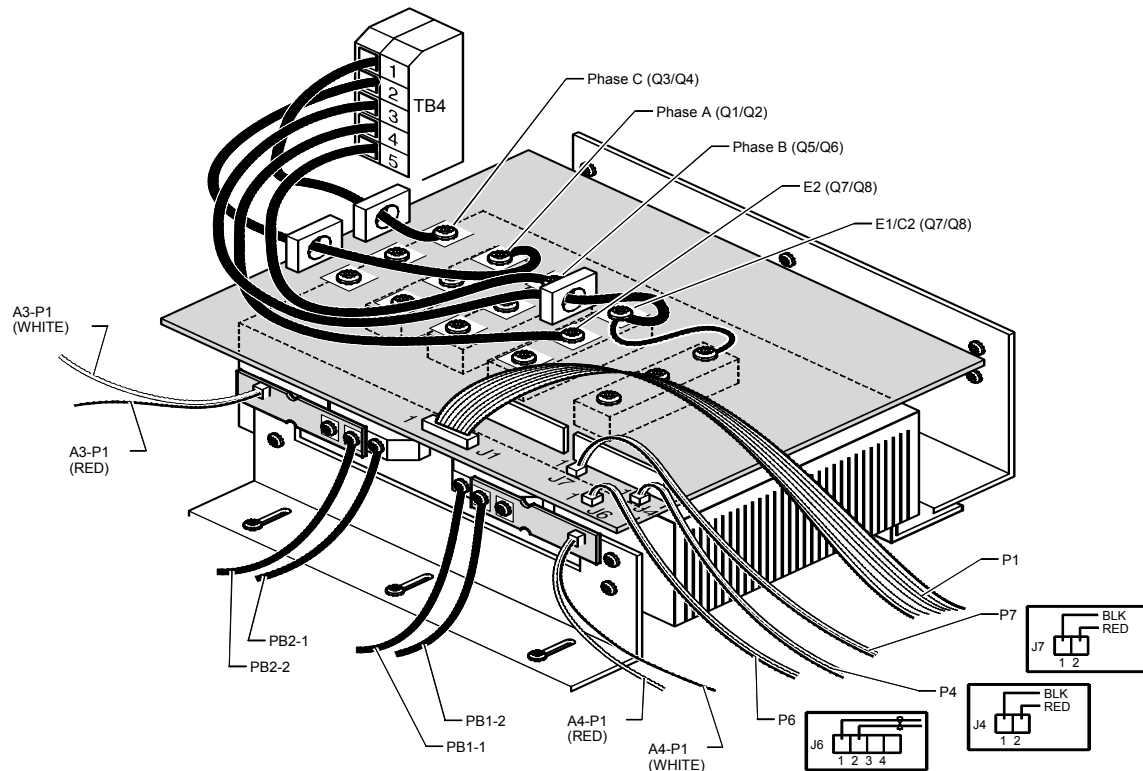

Figure 6-1. Heat Sink Assembly

6.3.3 All Other Parts

Verify that the cables are marked before disconnecting. Replace the defective part with the new part. Reconnect wiring the same way as it was disconnected.

6.4 Calling for Service

Call for service if you encounter any of the following conditions:

- **Repeated start-up attempts are unsuccessful.**
- **A UPS fault occurs that cannot be cleared.**
- **Normal operation of the critical load repeatedly causes an overload condition. This is not a UPS fault. A qualified person must analyze the total load connected to the UPS to prevent unit failure. Momentary overload conditions will be handled within the parameters of the UPS unit, but sustained overloads will cause the UPS Unit to fail.**
- **Any indicators or alarms operate abnormally or continuously.**
- **Any other abnormal function of the system occurs.**
- **If any abnormal battery condition is detected.**
- **When you are unsure of what action to take.**
- **If any of the above occurs:**
- **Fill out a service request form by calling our toll free number (800-726-4316).**



DANGER: Lethal voltages are present inside the equipment even when there appears to be no input power to the unit. Protect yourself from the risk of electrocution by referring service to qualified personnel only.

6.5 Customer Service and Support

Start-up, UPS maintenance, battery maintenance, and preventative maintenance programs are available through your Factory sales representative.

6.5.1 Start-Up Services

Various start-up services are available. Contact your sales representative or call our toll free number (800-726-4316).

6.5.2 Maintenance Agreements

Standard Full Service, 24/7 Full Service, and Extended On or OFF Site Maintenance agreements are available. Contact your sales representative or call our toll free number (800-726-4316).

6.5.3 Warranties

If you have any questions about the warranty on your UPS System or the batteries contact our toll free number at (800-726-4316).

Section 7. Troubleshooting

7.1 Troubleshooting Guide and System Alarms

Table 7-1

Case	Symptoms		Causes	Action
	Description	LCD Display		
1	Attempt to turn on and unit remains in BYPASS and LCD screen shows input OK	<div style="background-color: #0056b3; color: white; padding: 5px; font-family: sans-serif; font-size: 0.9em;"> UPS FAILURE @ ## KW INPUT OK @ CHRG OFF BATTERY OK @ DC OK ON BYPASS @ OUT BAD </div>	Output is short-circuited	Replace Heatsink assembly. If problem still persists, go to step 2.
			Heatsink assembly has failed	Disconnect all loads then turn the unit back on. If it runs normally, request facility manager to check output loads for possible short. If problem still persists, go to step 3.
			Not Listed	Call support at (800-726-4316) for further action.
2	Attempt to turn on and unit remains in BYPASS_ and LCD screen shows input BAD	<div style="background-color: #0056b3; color: white; padding: 5px; font-family: sans-serif; font-size: 0.9em;"> UPS FAILURE @ ## KW INPUT BAD @ CHRG OFF BATTERY OK @ DC OK ON BYPASS @ OUT BAD </div>	Connector P3 on control PCB gets loose	Check connector for proper seating. If problem still persists, go to step 2
			Connector P3 has bad connection	Unplug P3, verify voltages are present across pin 2 & 4 and 6 & 8 for NOVA and pin 1 & 2 and 3 & 4 for 3-phase. If no voltage is present, go to step 4. Else, go to step 3.
			Control PCB failure	Replace control PCB. If problem still persists, go to step 4.
			Not listed	Call support at (800-726-4316) for further action.
3	Contactor keeps cycling or chattering	<div style="background-color: #0056b3; color: white; padding: 5px; font-family: sans-serif; font-size: 0.9em;"> UPS PROBLEM @ ## KW INPUT BAD @ CHRG ON BATTERY OK @ DC OK ON INVERTER @ OUT OK </div>	Fluctuation in input voltage and frequency	Verify input voltage to be within + 10% and frequency to be + 3 Hz compared with nameplate spec. If these readings are OK, go to step 2.
			Contactor coil connector gets loose	Check contactor connections on control PCB. For single-phase, check P12, for 3-phase, check P15. If problem still persists go to step 4

Case	Symptoms		Causes	Action
	Description	LCD Display		
			Contactor coil failed	Unplug P15 (or P12 for single-phase) on control PCB to verify coil resistance on the harness side. If open circuit is found, replace the contactor. Else, go to step 4.
			Control PCB failure	Replace Control PCB. If problem still persists, call tech support at (800-726-4316) for further action.
			Heatsink assembly failure	Replace Heatsink assembly. If problem still persists, call tech support at (800-726-4316) for further action.
			Not listed	Call tech support at (800-726-4316) for further action.
4	Unit went into FAILURE mode	<div style="border: 1px solid black; background-color: #0056b3; color: white; padding: 5px; margin-bottom: 10px;"> UPS FAILURE @ ## KW INPUT OK @ CHRG ON or OFF BATTERY OV @ DC OV ON BYPASS @ OUT BAD </div> Or <div style="border: 1px solid black; background-color: #0056b3; color: white; padding: 5px;"> UPS FAILURE @ ## KW INPUT OK @ CHRG ON BATTERY LOW @ DC UV ON BYPASS @ OUT BAD </div>		Call tech support at (800-726-4316) for further action.

7.2 Using the LCD Display Panel

All units have the screens in Figure 7-2 and Figure 7-3. Units equipped with the optional output transformer also have the screen in Figure 7-4. All screens are updated continuously to provide you with up-to-the-minute status information.

When input power is applied to the unit, the LCD display panel lights up and displays the following message:



Figure 7-1. Message That Appears at Power-on

If your LCD display panel is not lit, the unit has a problem. Contact the factory service by calling our toll free number at (800-726-4316).

7.3 Default Screen 1

Figure 7-2 shows the first default screen. Table 7-2 describes the messages.

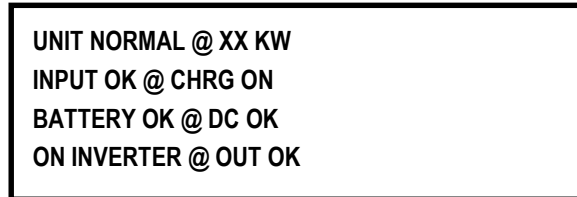

Figure 7-2. Default Screen 1

Table 7-2. Description of Default Screen 1

Line	Message	Description
1	UPS NORMAL @ 15 KW	<p>15 KW indicates the KW rating.</p> <ul style="list-style-type: none"> • STAND BY or NORMAL = normal operating modes. • STAND BY ALARM FAILURE = UPS alarm condition. • FAILURE = unit failed or persistent alarm condition. Shut off the system and wait for the LCD to go dark, then restart the unit.
2	INPUT OK @ CHG ON	<p>Shows one of the following conditions:</p> <ul style="list-style-type: none"> • INPUT OK = input within an acceptable range. • INPUT BAD = input out of range. • CHRG ON = charger on. • CHRG OFF = charger is off. This occurs if the input capacitor is open or the system is in a failure mode (UPS ALARM).
3	BATTERY OK @ DC OK	<p>Shows one of the following conditions. Note that the typical DC bus voltage should be higher than the battery voltage.</p> <ul style="list-style-type: none"> • BATTERY OK = battery voltage within an acceptable range. • BATTERY OV = battery voltage high. This is normal when the battery is charging. • BATTERY LOW = battery voltage low. Recharge battery. • DC OK = DC bus voltage within an acceptable range. • DC OV = DC bus voltage too high (UPS ALARM). • DC UV = DC bus voltage too low (UPS ALARM).

7.4 Default Screen 2

Figure 7-3 shows the second default screen. Table 7-3 describes the messages.

OUTPUT: ___ V @ ___ W
 INPUT: ___ V @ ___ A
 DC BUS: ___ V @ NA A
 BATT: ___ V @ + ___ W

Figure 7-3. Default Screen 2

Table 7-3. Description of Default Screen 2

Line	Description
1	Shows one of the following: <ul style="list-style-type: none"> • If an output transformer is not used, shows the output voltage and power in watts. • If an output transformer (T1) is used, shows the primary voltage of the output transformer (T1) (typically 208 VAC).
2	Shows input volts and amps.
3	Shows the internal DC bus condition (for factory use).
4	Shows the battery voltage. <ul style="list-style-type: none"> • (+) = current in Amps indicates charging Amps. • (-) = discharging Amps.

7.5 Default Screen 3

If the optional output transformer is installed, the following screen shows the multiple output voltages. Figure 7-4 shows the first default screen.

OUTPUT: 120 V @
 OUTPUT: 208 V @
 OUTPUT: 277 V @
 OUTPUT: 480 V @

Figure 7-4. Default Screen 3

Section 8. Options

This section provides detailed information about the options available for the **NOVA** Lighting Inverter.

8.1 Internal Manual Bypass Switch (Make Before Break)

➤ To move from UPS mode to Bypass mode

1. Turn off the battery breaker.
2. Move the manual bypass switch to the BYPASS position.

➤ To move the Bypass mode to UPS mode

1. Turn off the battery breaker.
2. Move the manual bypass switch to the UPS position.
3. Turn on the battery circuit breaker for normal operation.

8.2 External Wrap-around Manual Bypass Switch (same Input and Output Voltage)

The external maintenance bypass switch is mounted in a box that is field-installed and can be installed on adjacent wall. The single control simplifies the operation of the external manual bypass switch; however, operating instructions must be carefully observed before using the switch.

For ratings, wiring diagram, and enclosure dimensions, (see the figures on the following pages).

To access the operator control switch for the external manual bypass switch, open the cabinet front door. The manual bypass switch has three positions:

UPS – connects the critical load to the output of the inverter and establishes normal operation.

SBS – connects power to the critical load through the static bypass switch (for 0° phase angle synch).

BYPASS – connects power to the critical load through the bypass switch to bypass the inverter.

The BYPASS Switch is a 2 pole "MAKE BEFORE-BREAK". type. Contacts are Marked as

"UPS", "SBS", and "BYPASS".

Use the wrap-around bypass switch with same input and output voltage only. For different input/output systems, use a switch with an external transformer. A wraparound bypass switch can be used with systems without any “built in secondary distribution circuit breaker” within the unit

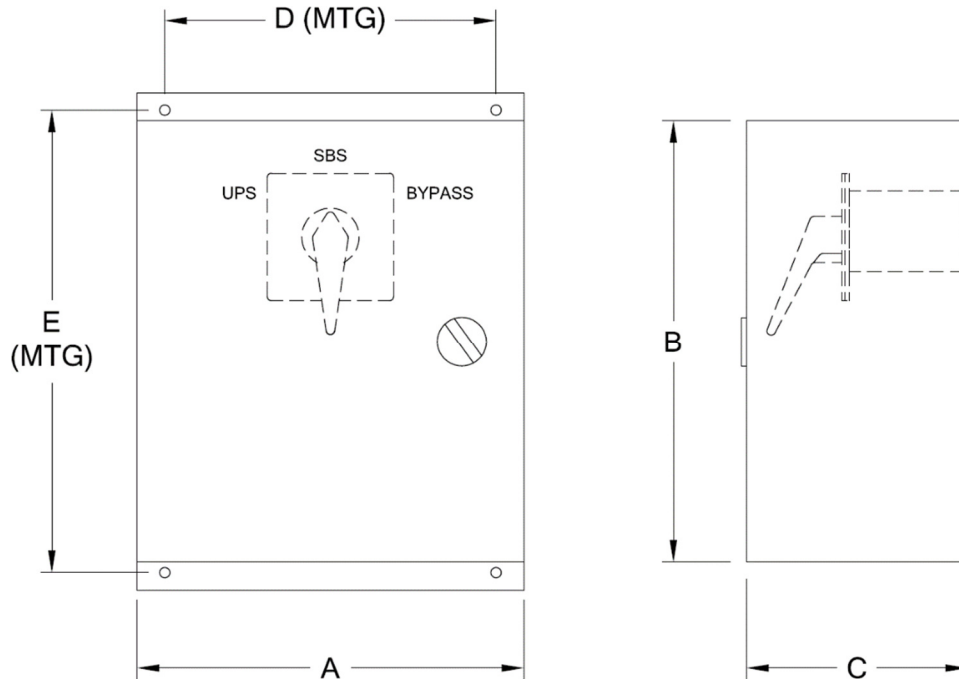

Enclosure Dimensions

Amp	Voltage Class	Dimension (inches)				
		A	B	C	D MTG	E MTG
55 AMP	600V	14	16	6	12	16.75
110 AMP	600V	14	16	10	12	16.75
175 AMP	600V	20	20	12	18.5	18.5



Note: Do not leave the switch in “SBS” position



Note: This option is offered for same Input / Output voltage only.



Note: Wraparound bypass switch can't be used with units that have “Internal Secondary Distribution Circuit Breaker”

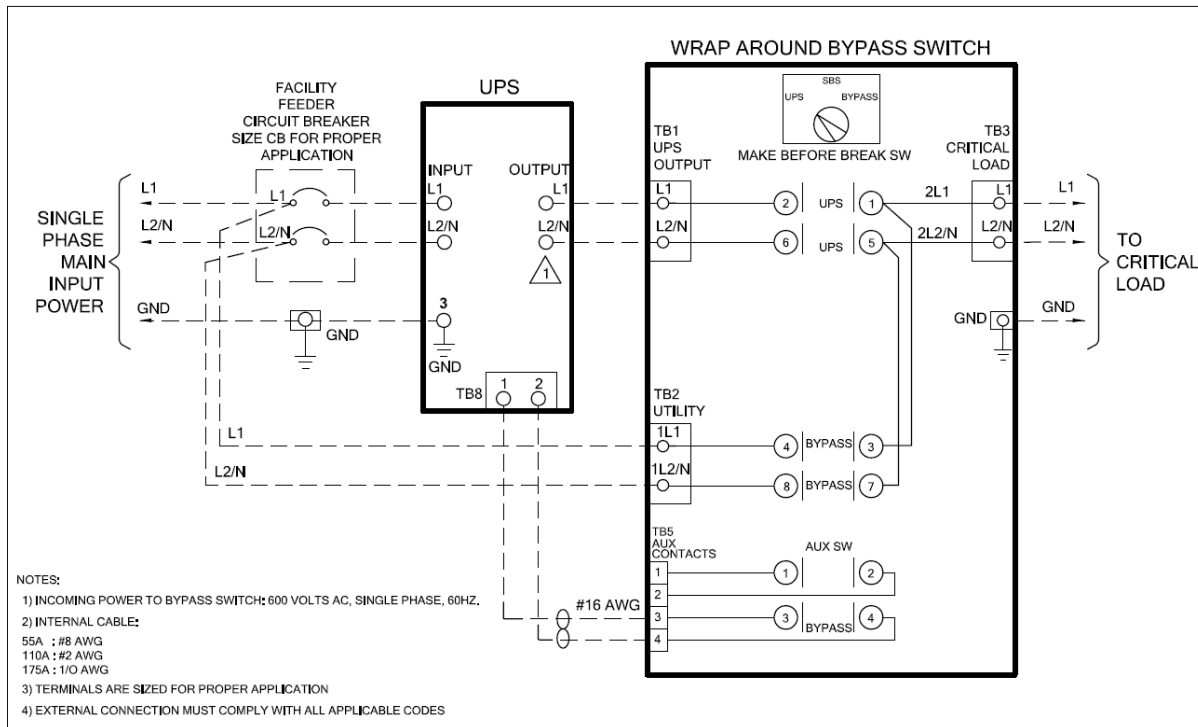

Maintenance Bypass Switch Wiring Diagram (Typical)

➤ **To install the maintenance bypass switch**

1. Always allow front access to the MBS box for maintenance and servicing.
2. Electrical codes require that the maintenance bypass switch box be installed with no less than 3 feet at the front of the cabinet.
3. Side and rear panels do not require service clearance; however, side vents must not be blocked.
4. Verify all power connections are tight.
5. Verify all control wire terminations are tight.
6. Verify all power wires and connections have proper spacing between exposed surfaces, phase-to-phase and phase-to-ground.
7. Connect Control wire TB5-3, and TB5-4 (Aux contact) to UPS cabinet Terminal Block (TB8-1, TB8-2) Ext Bypass Sync using 22 AWG.
8. Verify that all control wires are run in individual, separate steel conduit.



DANGER: All power connections must be completed by a licensed electrician who is experienced in wiring this type of equipment. Wiring must be installed in accordance with all applicable national and local electrical codes. Improper wiring may cause death, injury, explosion, fire, or damage to the equipment. Verify that all incoming high and low voltage power circuits are de-energized and locked out before installing cables or making any electrical connections.

8.3 Audio Alarms with Silence Switch

The audio alarms with silence switch provides an audible warning signal, acknowledge, and reset for Input Fail, On Bypass, Inverter On, Low Battery and Summary Alarm for any of the foregoing alarm conditions.

8.4 Remote Status Panel

The remote UPS status panel is a console mount style box that can also be wall mounted. It comes in a black finish and includes a 10-foot-long cable for hard wiring to TB9 terminal block. An optional length cable up to 1000-feet long is also available.

The remote status panel has the following status LEDs.

- **INPUT OK** = input power is within acceptable range.
- **INVERTER ON** = inverter is ON.
- **ON BYPASS** = unit is in bypass mode.
- **ON BATT** = unit is operating from battery power.
- **LOW BATT** = battery voltage is low prior to shut down.
- **SUM ALARM** = unit is experiencing a critical alarm such as an over-temperature condition.
- **HORN** = audible warning for an alarm condition.
- **SILENCE SWITCH** = silences the audible warning.

An LED TEST push-button allows you to test the LEDs.

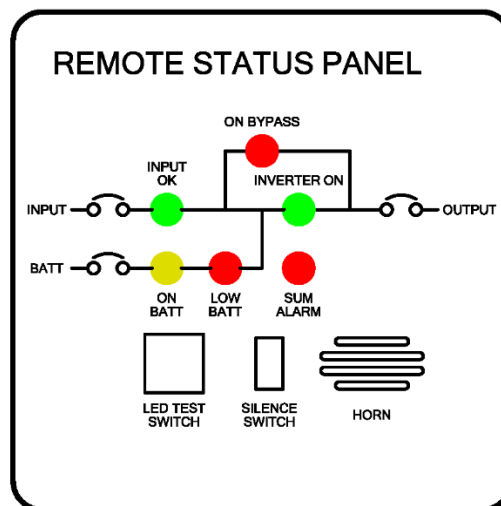

Remote Status Panel

Refer to Figure 8-1 for Interface terminal blocks.

8.5 Transient Voltage Surge-Suppressor (TVSS)

The TVSS contains energy-absorbing components designed for specific line configurations. If protection components become damaged by absorbed transients, the device shows a reserve flag that indicates a need for replacement. The unit remains operational, but without surge protection.

8.6 Offline Inverter Operation

The offline inverter operation consists of a slow transfer unit and a fast transfer unit.

8.7 Normally ON/OFF Output Aux. Circuit Breakers

These 1-pole, 20A circuit breakers are designed to protect customer circuits and are offered as the following options:

- **Normally ON C.B. option**
- **Normally OFF C.B. option**
- **Normally OFF Delay C.B. option**

Standard output aux breakers are 10KAIC @ 120/240 volt, 6 KAIC @ 277 volts. Normally, ON/OFF.

8.8 Main Input CB Standard/Higher KAIC

This option consists of an input circuit breaker, standard, and higher KAIC.

8.9 Main Output CB Standard/Higher KAIC

This option consists of an output circuit breaker with higher KAIC.

8.10 Higher KAIC Normally ON/OFF Aux Output Circuit Breaker

Molded case type.

8.11 Power Flow Mimic

The power flow mimic option allows unit power status verification at-a-glance. Six LEDs indicate the following conditions:

- Green = Input OK or inverter is ON.
- Yellow = On battery, or on bypass.
- Red = Low battery or summary alarm.

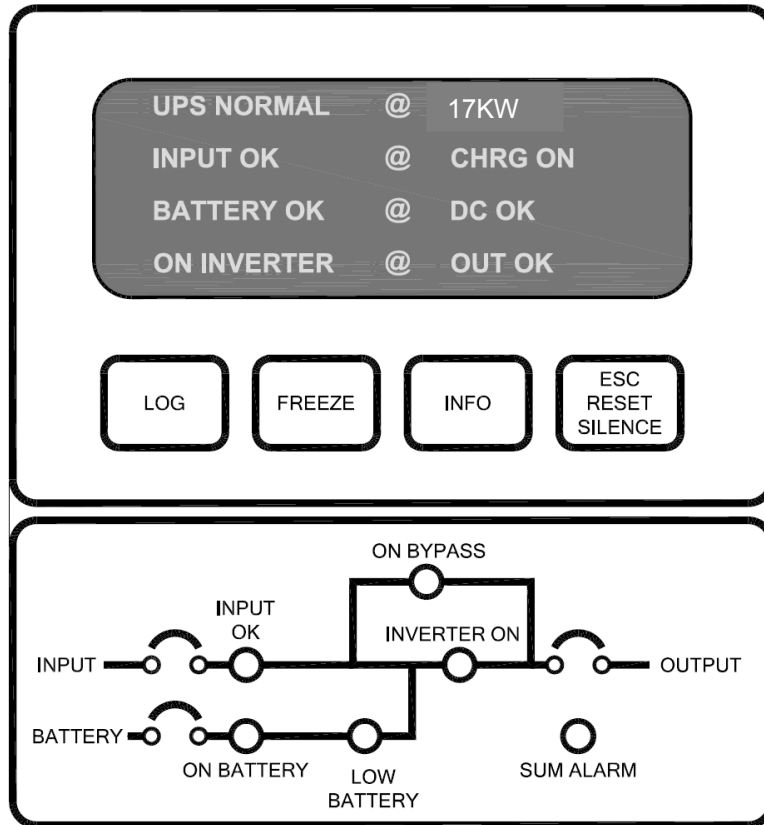

Power Flow Mimic

8.12 Global Monitoring Systems (GMS)

1. Monitoring, Local On UPS – Event log

The control and monitoring PCBA collect event data and displays up to 100 of the most recent date- and time-stamped events. When the log is full, the oldest events are rolled off.

Keypad functions and resulting screens are presented below:

LOG – press to display the event log. All stored events scroll continuously on display. Press this key again to redisplay the main menu.

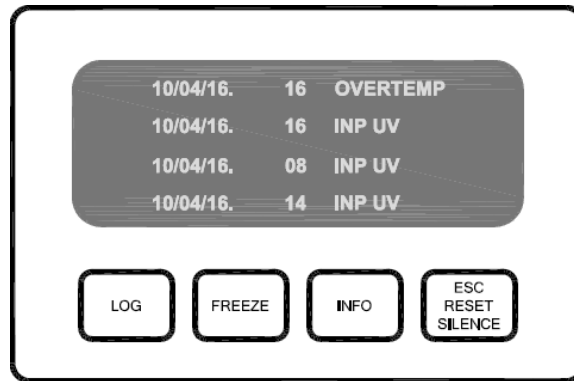

Example of Logged Events

- **FREEZE** = press to freeze the default monitoring and alarms screen temporarily. Press this key again to return the display to the initial scrolling menu.

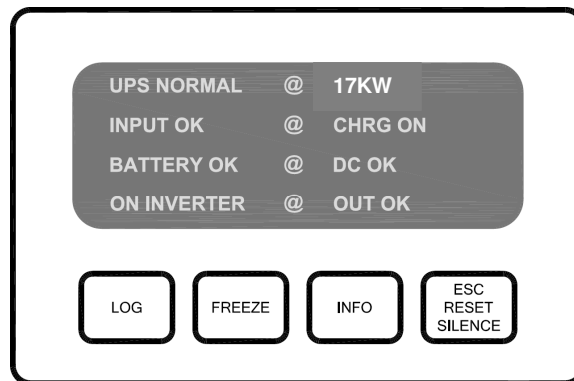

Example of Status Screen

- **INFO** = press to display system data on the screen. Press this key again to return to the default screen.

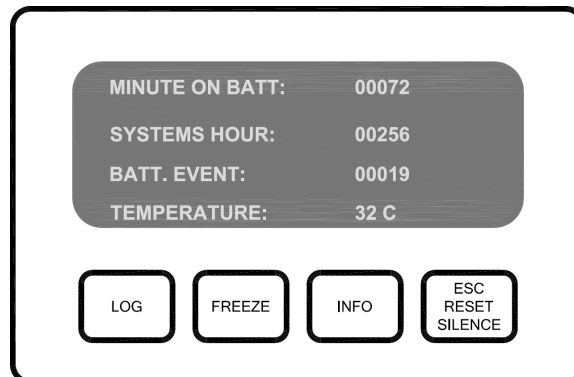

Example of System Info Screen

- **RESET and INFO = press these keys at the same time to clear the display.**

2. Monitoring, Local On UPS - Aux CBs Trip Monitor
Trip signals from the breakers are displayed on the circuit breaker trip screen. The circuit breaker is a part of default monitoring and alarm display that scrolls continuously when the unit is in operation.

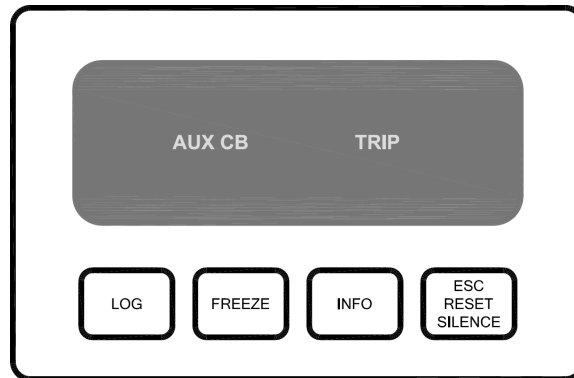

8.12.1 Local Monitoring via PC with RS-232

The local monitoring via PC with RS-232 option requires a PC and LabView monitoring software. The software is provided on a disc that installs easily on any Windows operating system. An attached cable of a specified length plugs into a PC serial port and connector J6 on the Control Board located inside right door. LabView software must be configured to use COM port 1.

The LabView software translates data protocol coming to COM port from an active unit via the RS-232/RS-485 interface and displays the parameters and active alarms on a PC monitor. The following figure shows an example of a PC screen with measured parameters and actual unit status.

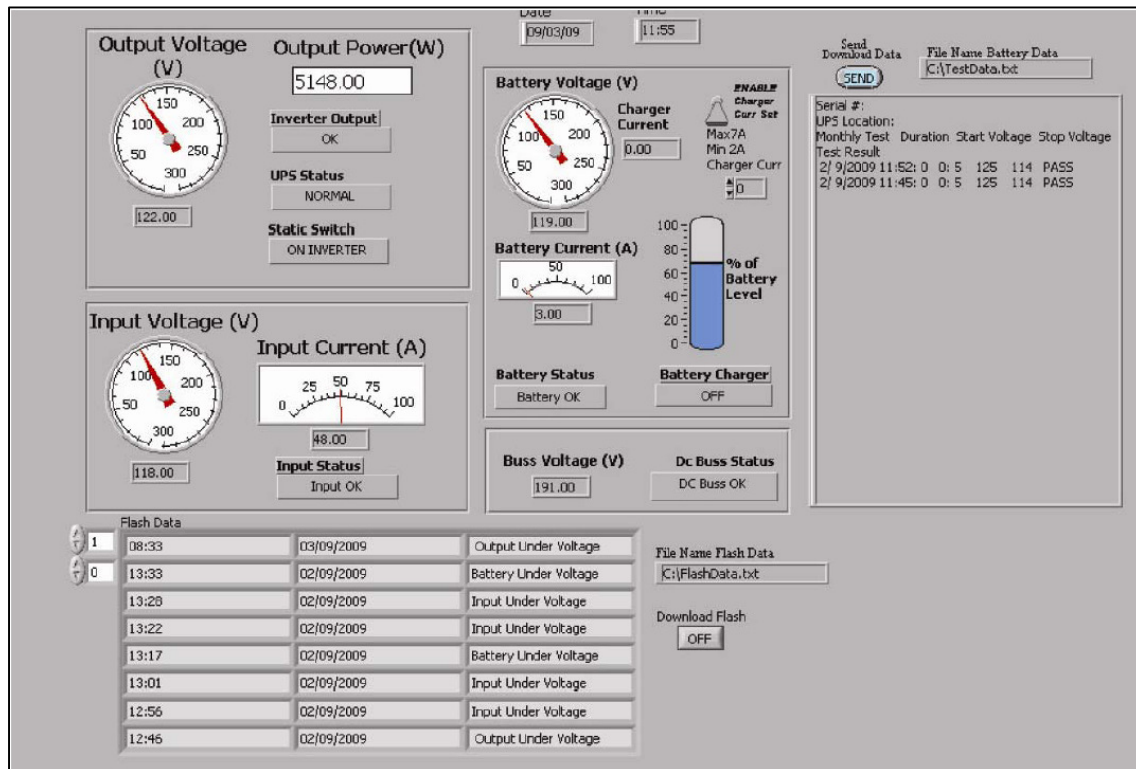

8.12.2 Local Monitoring via PC with RS-485

This option is similar to the local monitoring via PC with RS-232 option, except that an RS-485 cable is used instead of an RS-232 cable.

8.12.3 RJ45 Ethernet connection

8.13 Simple Network Management Protocol

This option consists of a basic SNMP NetAgent mini-external device as an advanced SNMP NetAgent device.

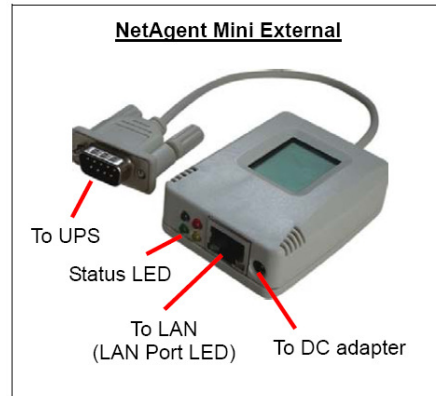

Example of Basic NetAgent Mini-external Device



Example of Advanced NetAgent Device

This option is available in the following offerings:

- **Basic NetAgent SNMP with WI-FI HUB application**
- **Advance NetAgent SNMP with WI-FI HUB.**
- **Advance NetAgent SNMP with GPRS mobile modem.**
- **Advance NetAgent SNMP with dial-up modem**

The following figures show examples of how this option can be used. In these figures, NetAgent mini and NetAgent II SNMP modules are installed inside the front door of the inverter cabinets.

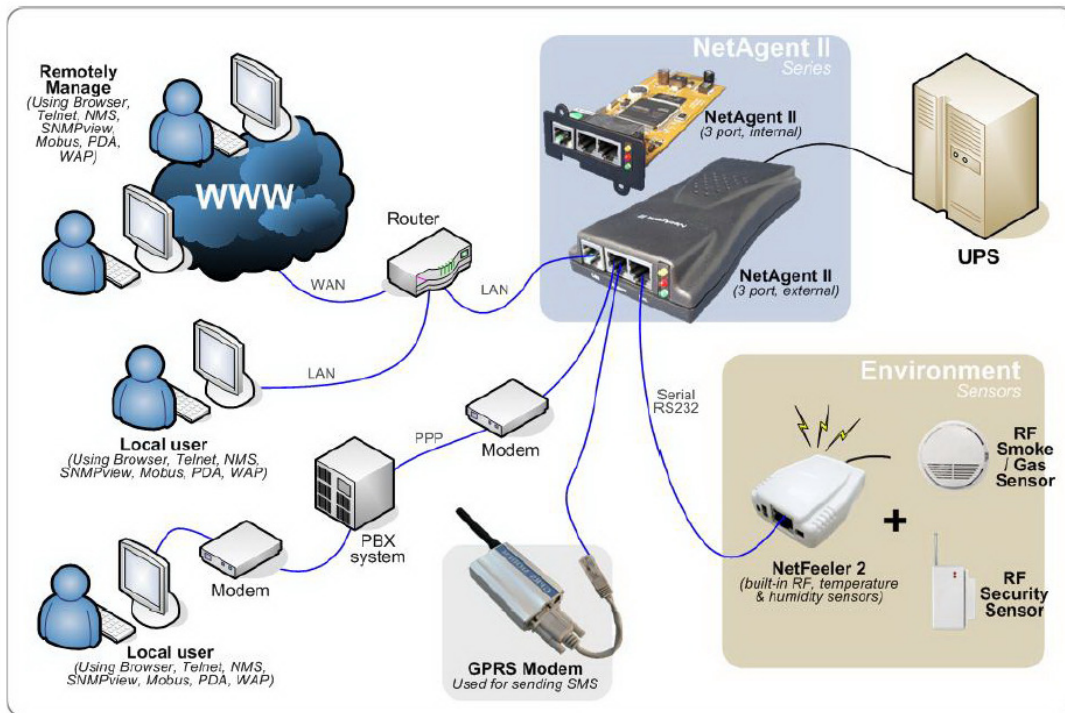
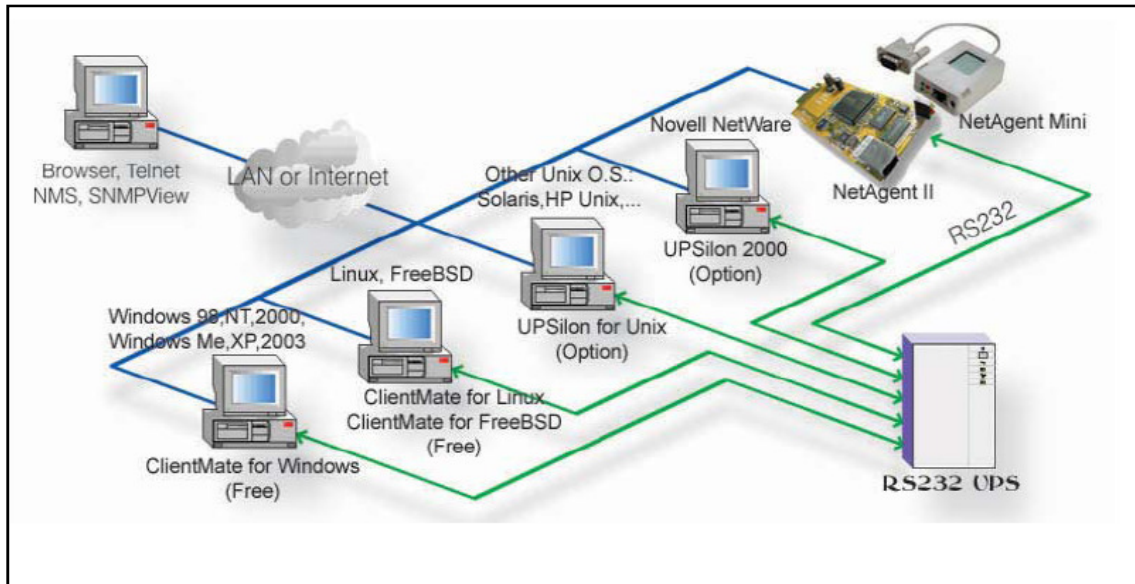

8.14 Seismic Mounting Bracket

The seismic floor mounting bracket includes one left bracket and one right bracket per cabinet.

8.15 Battery String Monitoring (Wireless).

The wireless battery monitoring system continuously monitors and communicates with the data collector to provide Real-time data. It analyzes and stores battery string voltage, current and (optional) cabinet temperature. For detail information request literature or visit our website.

8.16 Battery (Individual) Monitoring (Wireless)

The wireless battery monitoring system for individual battery block monitors each battery voltage, battery impedance and (optional) battery temperature. For detail information request literature or visit our website.

8.17 Form "C" N/O Contacts for Alarms

The optional alarm relay board has a terminal strip TB for user connection to the individual alarm contacts. The Remote Contact Board includes isolated Form C contacts for the alarm signals in the following table.

Terminal Number	Signal	Description
TB30-1	LOW BATTERY	N/O contact that closes when the unit is on battery operation and the batteries approach inadmissible discharge status.
TB30-2	ON BYPASS	N/O contact that closes when the unit transfers the load to static by-pass.
TB30-3	SUMMARY ALARM	N/O contact that closes when the unit has any one of the following alarm conditions. Internal Failure, System Overheat, Battery under-voltage.
TB30-4	COMMON	Common Terminal
TB30-5	INPUT FAIL	N/O contact that closes upon loss of input power.
TB30-6	NOT USED	—

Refer to Figure 8-1 for Interface terminal blocks.

8.18 Dry Contact, N/O or N/C Contact with Isolated Common

Terminal Number	Signal	Description
TB18-1 (COM)	SUMMARY ALARM	

Terminal Number	Signal	Description
TB18-2 (N/O)		When the unit has any one of the following alarm conditions. Internal Failure, System Overheat, Battery under-voltage.
TB18-3 (N/C)		
TB18-4 (COM)	ON BYPASS	When the unit transfers the load to static by-pass.
TB18-5 (N/O)		
TB18-6 (N/C)		
TB18-7 (COM)	LOW BATTERY	When the unit is on battery operation and the batteries approach inadmissible discharge status.
TB18-8 (N/O)		
TB18-9 (N/C)		
TB18-10 (COM)	INVERTER ON	Upon Inverter turned ON
TB18-11 (N/O)		
TB18-12 (N/C)		
TB18-13 (COM)	ON BATTERY	Upon loss of input power.
TB18-14 (N/O)		
TB18-15 (N/C)		
TB18-16 to TB18-18	Spare	

Refer to Figure 8-1 for Interface terminal blocks.

8.19 Battery Thermal Runaway Control

This option provides protection in case of over-temperature condition in the battery compartment. If such a condition occurs, this option shuts off the charger. Charging resumes when the temperature returns to normal. A dry contact (N/O, N/C) relay interface is provided for this option for user interface per following:

Terminal Number	Signal	Description
TB121-1	N/C	N/C contact that opens when the critical temperature has reached
TB121-2	COM	Common
TB121-3	N/O	<ul style="list-style-type: none"> N/O contact that closes when the critical temperature has reached

- Refer to Figure 8-1 for Interface terminal blocks.

8.20 Battery Breaker alarm

It provides a signal when the battery breaker is in OFF position.

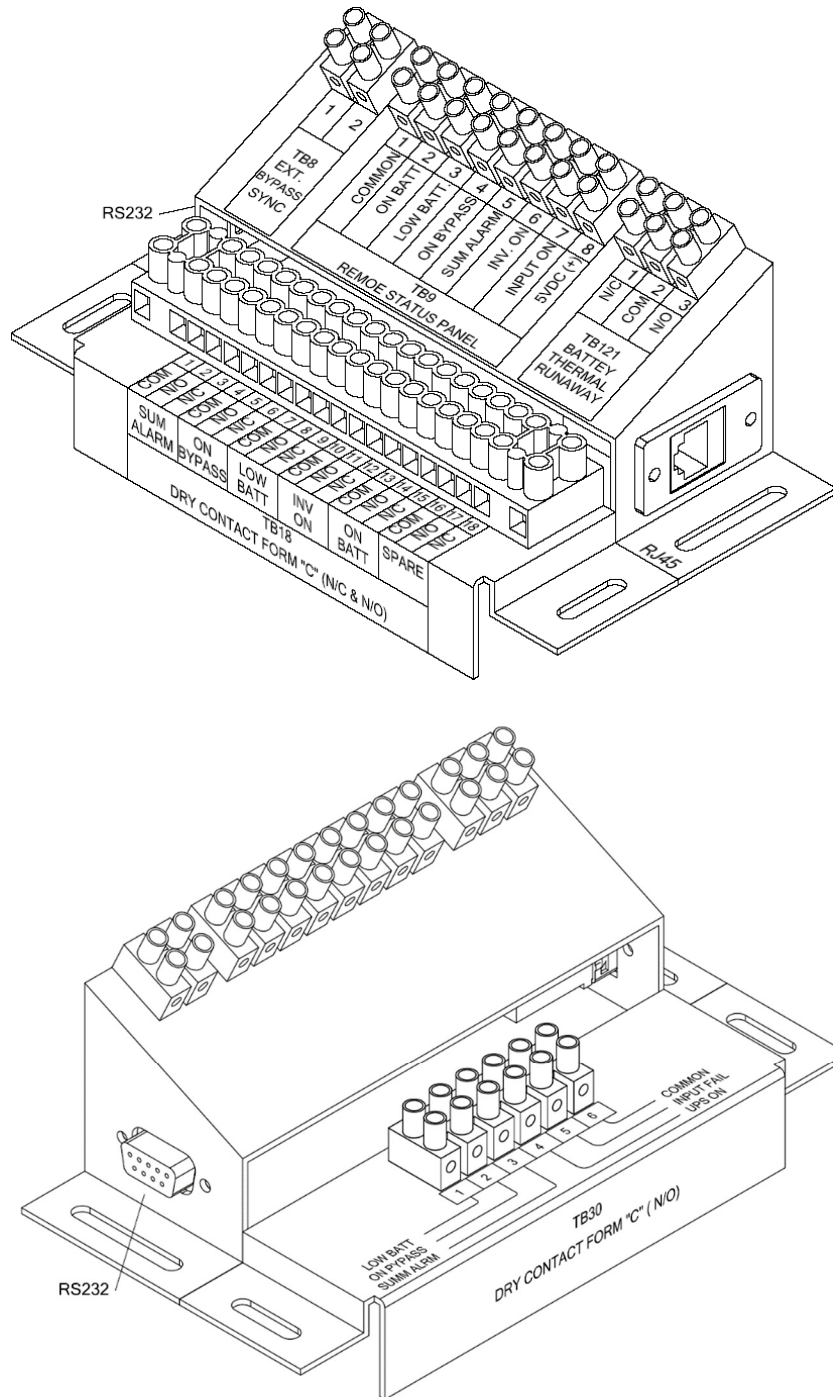

Figure 8-1 (Communications and Alarm Signaling Interfaces)

APPENDIX A - SPECIFICATIONS

Typical Specifications (Input / Output Current)

1-Phase Input Current															
kW	6.0			8.0			10.0			15.0			17.0		
Voltage (vac)	208V	240V	277V	208V	240V	277V	208V	240V	277V	208V	240V	277V	208V	240V	277V
Max Current	43	36	31	48	42	36	64	56	48	95	83	71	107	94	80
1-Phase Output Current															
kW	6.0			8.0			10.0			15.0			17.0		
Voltage (vac)	208V	240V	277V	208V	240V	277V	208V	240V	277V	208V	240V	277V	208V	240V	277V
Max Current	29	25	32	38	34	28	48	42	36	72	63	54	91	82	61

General Specification

Input	
Voltage Regulation	+10% -15%
Frequency (Hz)	60 Hz \pm 3%
Power factor	0.98 to 1.0 (Typical)
Overcurrent protection	Electronic / Circuit Breaker
Number of wires	2 Wires plus Ground
Power connection	Hard Wired (Terminal Block)
Output	
Voltage (vac)	NOVA - 120/208/240/277 VAC
Voltage regulation	\pm 3% No Load to Full Load; \pm 3% High Line to Low Line
Frequency (Hz)	60 Hz \pm 0.5 Hz (When on Inverter)
Waveshape	Sine Wave
Harmonic distortion	<5% THD; <3% Single Harmonic
Crest factor	Up to 3 to 1
Power factor	0.65 Lagging or Leading to Unity
Overload	115% overload for 5 to 10 minutes, 125% for 30 seconds.
Protection	Electronic / Circuit Breaker
Noise rejection	-120 dB Common Mode; -60 dB Normal Mode
Number of wires	2 Wires plus Ground
Power connection	Hard Wired (Terminal Block)



Battery

Battery run time	90 minutes minimum				
Battery type	Sealed, Maintenance-Free, AGM, VRLA type				
Unit Rating (KW)	6	8	10	15	17
Nominal dc voltage	144 VDC	192 VDC	192 VDC	240 VDC	240 VDC
Overcurrent protection	Circuit Breaker				
Packaging	Batteries Housed in Same Enclosure and/or additional battery cabinet for other battery run time				

Monitoring and communications

LCD Screen	Input Voltage; Battery Charger; UPS Output; On Battery; Low Battery; Summary Alarm
Indicators	LCD Display Panel (Back lit)
Relay interface	Dry Contacts for: Low Battery, On Bypass, Summary Alarm, Input Fail
Contact rating	125 Volts (AC or DC) Maximum; 1.25 Amperes Maximum; 30 Watts / 50 VA Maximum
Interface connection	Hard Wired (Terminal Block)

Environmental

Surge with standability	ANSI C62.41-1980 categories A & B				
Operating temperature	Meets NEMA requirements				
Operating relative humidity	0 to 95% non-condensing				
Altitude	Up to 6,000 feet (1,829 meters) with no de-rating				
Cooling	Air cooled-forced air (fan)				
Physical					
Unit Rating	6KW	8KW	10KW	15KW	17KW
Dimensions (inches) W x H x D	39 x 68 x 18	51 x 70 x 30.5			
Construction	Painted Steel Enclosure, Lockable Double front door, Full length hinged, for indoor installation,				
Color	Black				
Accessibility	Front all Servicing is through the front no side or rear access required				



NOVA
6, 8, 10, 15 & 17KW

Cable entry	Sides and top
Mounting	Four (4) mounting holes are provided for anchoring to floor, Hardware to be supplied by others
Due to continuous product improvement, this document is subject to change without prior notice.	

APPENDIX B - BATTERY CONNECTIONS

This appendix shows typical battery connection diagrams. The figures are provided for electrical connection only and do not necessarily match the actual battery layout in your unit. The arrangement may be different from the figures. Each system is shipped with its own battery connection diagram located inside the front door pocket.



DANGER: The use of a physically damaged battery can cause a catastrophic system failure and can even result in a fire or explosion that could endanger life and property. Before accepting a battery shipment from the carrier, please read and follow these instructions:

1. **Thoroughly inspect each battery for any signs of damage. If there is any damage, reject the shipment and notify the manufacturer. If possible, photograph the damage for future reference.**
2. **As you unpack the pallet or container, check each battery box for damage on all sides, the top and bottom. If there is any sign of damage, photograph the damage if possible, and contact Beghelli USA.**
3. **Before you install each battery in the cabinet, remove it from its carton and thoroughly inspect it again on every side, the top and bottom for any signs of physical damage including, but not limited to, cracks, chips, leaks, bulges, and so forth.**
4. **If a battery is dropped or makes hard contact with any object, inspect it again.**
5. **Batteries are heavy, so exercise care when lifting them on to the shelves.**
6. **Use of any non-Factory Tested/UL924 Certified batteries, including those with similar brand name and part number, will void the systems UL 924 Safety Certification Listing. Please call or e-mail Power Services for tested/certified replacement batteries.**
7. **If at any time you have any questions regarding the condition of a battery, set it aside and notify the manufacturer by calling our toll free number at (800-726-4316). Do not use a questionable battery under any circumstances, even temporarily.**

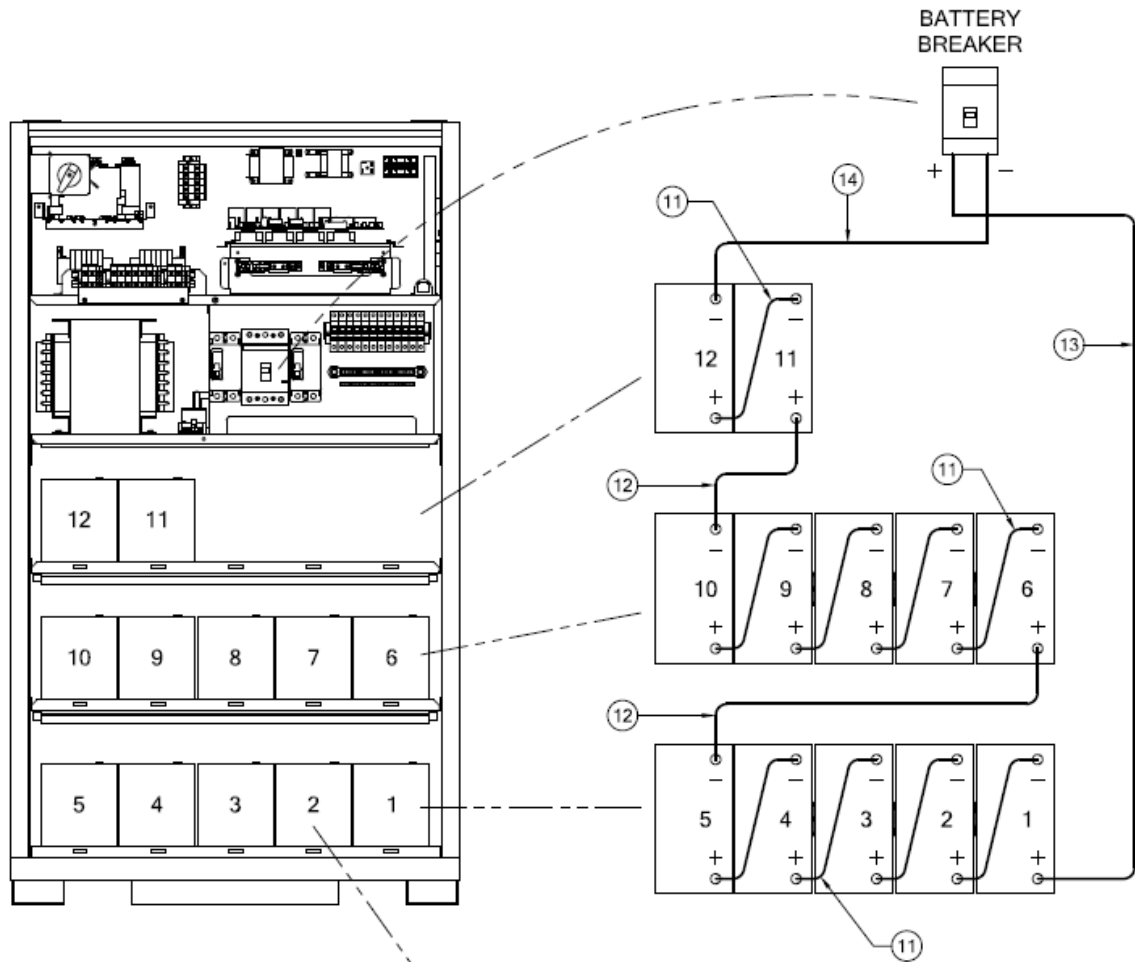

144 Volt Nominal DC Voltage (1 String of 12 Battery Typical)

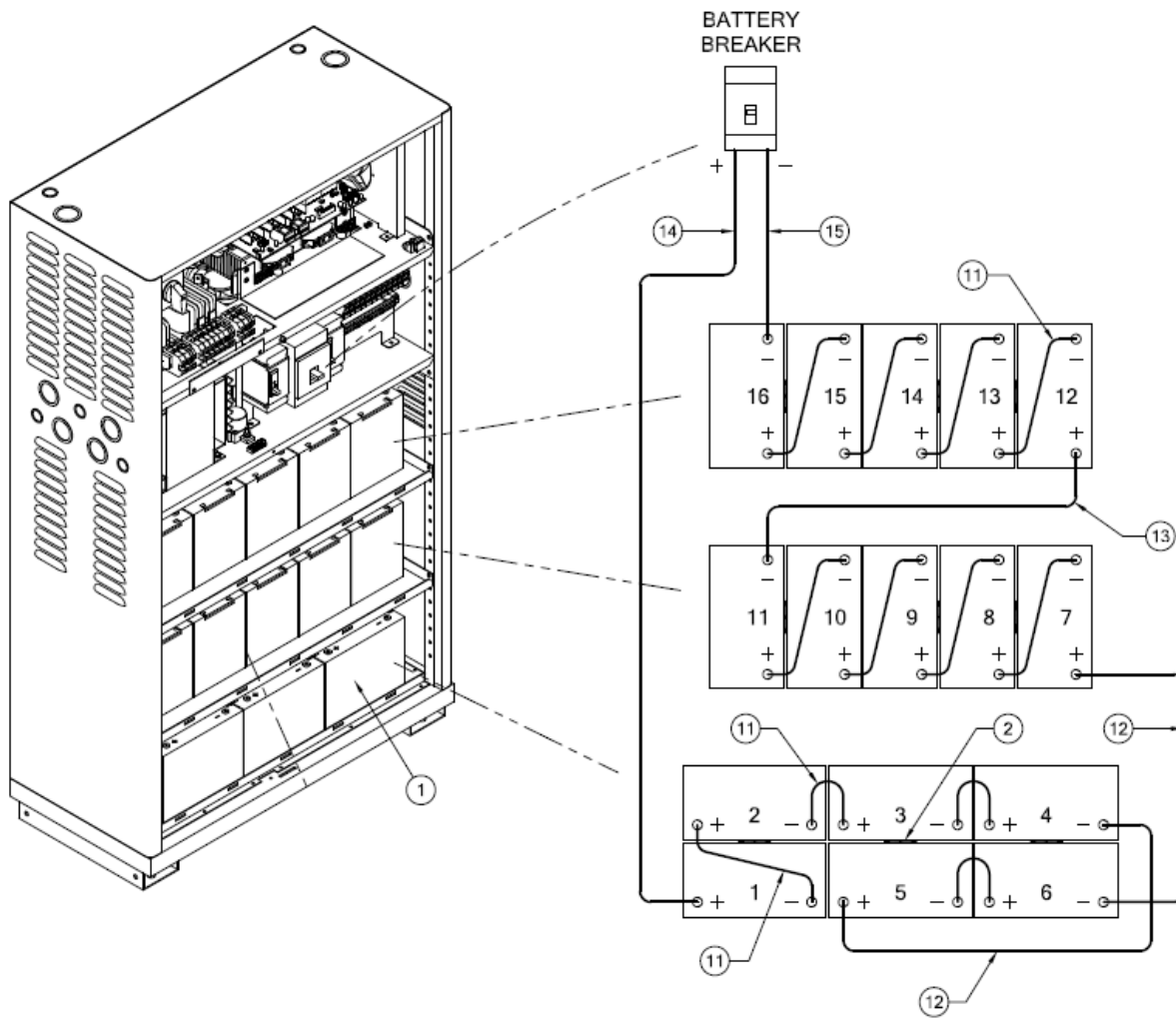

192-Volt Nominal DC Voltage (1 String of 16 Batteries 39" Cabinet Typical)

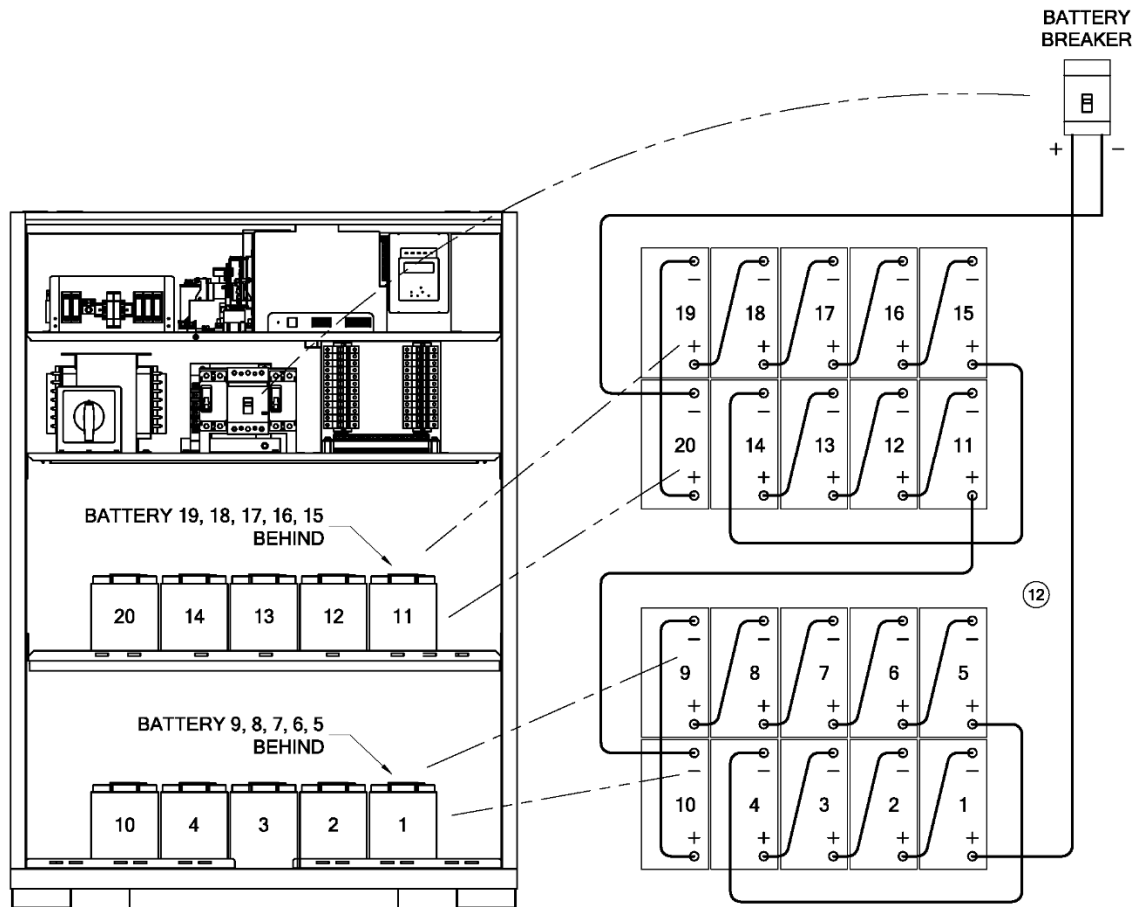

240-Volt Nominal DC Voltage (1 String of 20 Batteries Typical)

Index

A		F	
Alarms, 21		Features, 12	
Alerts, 20		First-time power-up, 41	
Audience, 5		Floor load ratings, 30	
B		FRU replacement, 50	
Battery		Functional description, 18	
connections, 38		H	
maintaining, 46		Handling, 30	
recharging, 39		Heat sink assembly, replacing, 51	
terminals, 49		I	
Battery Monitoring, 72		Inspecting the shipment, 30	
C		Installation	
Cabinet dimensions		climatization, 31	
standard series, 10, 11		K	
Cabling, 31		Key components, 14	
Calling for service, 53		L	
Climatization, 31		LCD display panel, 56	
Components		M	
key, 14		Maintaining batteries, 46	
Controller board, replacing, 51		Maintenance	
Customer service and support, 53		preventative, 46	
D		Maintenance agreements, 53	
Delivery, 30		Modes, 20	
Delivery space requirements, 22		Monitoring, Local On UPS - Aux CBs Trip Monitor, 68	

Monitoring, Local On UPS – Event log, 66

Mounting, 31

N

Normal mode, 20

O

Offloading the system, 30

Operating environment, 29

Operator's log, 46

Options

 details, 61

Output loads, 21

Output transformer

 messages on the LCD display panel, 60

P

Power connections, 49

Power Flow Mimic, 65

Preventative maintenance, 46

Product description, 10

R

Recharging batteries, 39

Replacing

 controller board, 51

 heat sink assembly, 51

Requirements

 delivery space, 22

Response to input power failure, 20

S

Seismic Brackets, 11, 12

Service, 6, 53

Shipment

 inspecting, 30

 unpacking, 31

Site considerations, 26

Standby mode, 20

Starting the unit

 after planned shutdown, 44

 first time, 41

Start-up services, 53

Storing the system, 39

System

 cabling and mounting, 31

 climatization, 31

 features, 12

 functional description, 18

 key components, 14

 offloading, 30

 storing, 39

 theory of operation, 20

System blocks, 18

T

Testing the UPS, 46

Theory of operation, 20

Troubleshooting Guide and System Alarms, 55

Turning off the unit, 44

U

Unpacking, 31

UPS

alarm, 21

alert, 20

UPS testing, 46

W

Warranties, 54

Warranty registration and warranty certificate request,
5

Z

Zone 4 Installation, 11, 12