

INSTALLATION INSTRUCTIONS

DUAL HEAD LED EMERGENCY LIGHTING FIXTURE

CAUTION: The battery in this unit may not be fully charged. After electricity is connected to unit, let battery charge for at least 24 hours, then normal operation of this unit should take effect. To check, press the TEST button. The lamps on the unit should turn on.

READ AND FOLLOW ALL SAFETY INSTRUCTIONS

IMPORTANT SAFEGUARDS: When using electrical equipment, basic safety precautions should always be followed, including the following:

1. Consult local building code for approved wiring and installation.
2. Disconnect AC power before servicing and installation.
3. Do not mount near gas or electric heaters.
4. Do not use outdoors.
5. Do not use this equipment for anything other than its intended use.
6. The use of accessory equipment not recommended by the manufacturer will void product listing and warranty and may cause an unsafe condition.
7. Any service on this equipment should be performed by qualified personnel only.
8. Equipment should be mounted in locations and at heights where it will not be subject to tampering by unauthorized personnel.
9. Use caution when servicing batteries. Battery acid can cause burns to skin and eyes. If acid is spilled on skin or in eyes, flush acid with fresh water and contact a physician immediately.
10. Cap unused wires with enclosed wire nuts or other approved method.
11. Make sure wire terminations are secure and leads are properly tucked in appropriate wire channels.

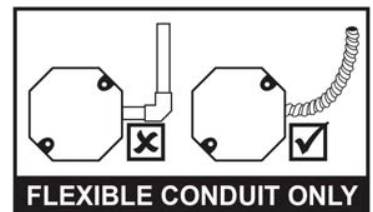
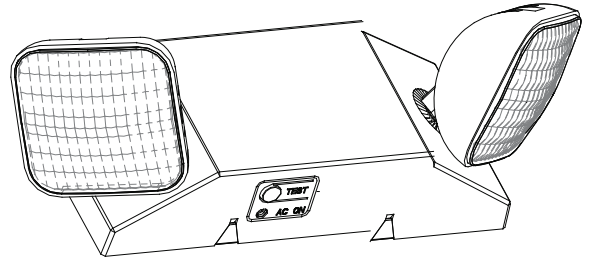

INSTALLATION:

1. Before starting installation, make sure that AC power is turned OFF.
2. Remove unit's back plate by pushing through the two tabs at the bottom using a narrow screwdriver.

J-BOX MOUNTING:

1. Feed fixture leads through the back plate and connect to AC power supply (Fig A). For 120V use black and white wires and for 347V, use red and white wires.
2. Attach back plate to J-Box and secure with screws.
3. Complete the battery connection. (Fig. B)
4. Align snaps and push housing directly onto the back plate (Fig. C). Apply continuous AC power and test the unit.

CONDUIT MOUNTING:

1. Secure back plate to wall surface. Route wires through hole in conduit flange and make conduit connection. For 120V, use black and white wires and for 347V, use red and white wires.
2. Complete the battery connection (Fig. B).
3. Align snaps and push housing directly onto the back plate (Fig. C). Apply continuous AC power and test the unit.

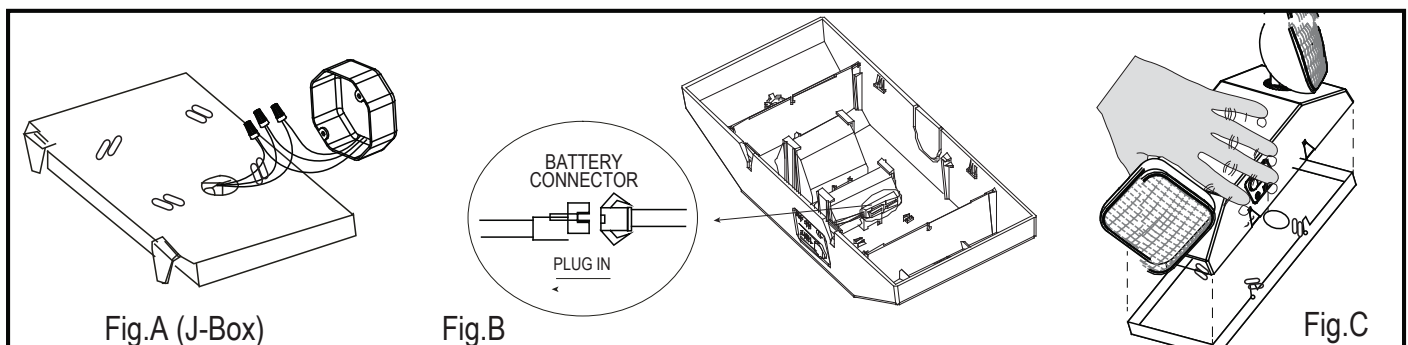

SAVE THESE INSTRUCTIONS!

INSTALLATION INSTRUCTIONS

WALL MOUNTING:

1. Secure back plate to wall surface using keyhole knockouts on the back.
2. Feed fixture leads through back plate and connect to AC power leads. Reference wiring diagrams below for proper wiring connections. Use a wirenut to cap off the unused lead.

OPERATION:

1. Apply AC power to the unit. The LED Indicator should turn RED.
2. After the battery has been left to charge for 2 hours, test the unit by pushing the switch. The LED indicator turns OFF and the lamps on the unit turn ON.
3. When the switch is released, the lamps turn OFF and the LED indicator turns back to RED.

TESTING:

National Electric Code (NEC) and NFPA life safety code regulations require that routine tests need to be performed as listed below: Once every month, the unit needs to be tested for duration of 30 seconds. Push in and hold the test switch to perform this test. Once every 12 months, a full 90 minute test (per UL requirements) needs to be performed on the unit. Disconnect power to the unit and leave it in the emergency mode. The lamps should stay ON for at least 90 minutes. Written records of the testing are to be kept for examination by the authority having jurisdiction.

TROUBLE - SHOOTING:

Condition - The emergency lights do not operate

1. If the charge indicator light is OFF: Check that the circuit breaker for AC supply is ON.
2. If the charge indicator light is ON: Check that battery is properly connected. If problem persists, Replace battery.
If remote lamps (where applicable) are connected to the equipment, then turn OFF the AC supply and disconnect the remote circuit wires from the equipment. Turn ON the AC supply and depress the test switch. If the local lamps (mounted on the equipment itself) come ON, then check the remote circuit for short or overload condition and correct as required. Reconnect the circuit wires and restore AC power. If the local lamps don't turn ON after disconnecting the remote circuit wires, then replace battery.

Condition - Emergency lights are dim

1. Battery not fully charged. Allow battery to recharge for 24 hours and then retest. If lights are still dim, replace battery.

MAINTENANCE:

Caution: Always turn OFF AC power to the equipment before servicing. Servicing should be performed only by a qualified service technician. Use only MANUFACTURER supplied replacement parts.

1. **BATTERY:** The battery supplied in this equipment requires no maintenance. However, it should be tested periodically (see TESTING) and replaced when it no longer operates the connected fixtures for the duration of a 30-second or 90-minute test. The battery supplied in this equipment has a life expectancy of 5-7 years when used in a normal ambient temperature of 72°F.
2. **OTHER:** Clean lenses and replace lamps, as and when required.

WIRING DIAGRAMS:

