

Project: \_\_\_\_\_ Type: \_\_\_\_\_  
 Model: \_\_\_\_\_ Date: \_\_\_\_\_



Display panel

## ■ specifications: internal

With the **NOVA UACP**, normally on lighting can be converted into emergency lighting in the event of a power failure. Often times, normal lighting will even provide greater illumination on the path of egress for added safety. Eliminate the need for remote heads and improve the aesthetics of the space using this alternative method of egress lighting. With the **NOVA UACP** providing output AC power, the DC line voltage drop concern of a battery pack is eliminated. The **NOVA UACP** is suitable for LED, fluorescent, incandescent, and most compact fluorescent lighting. The surge peak lighting load is 6000W for 0.5 seconds. It is important to take the peak load into consideration when choosing your load type.

## ■ specifications: external

The **NOVA UACP** is constructed from a durable 14 gauge steel housing. Stamped conduit knockouts are standard, and an optional 120VAC removable line cord is optional on all **NOVA UACP** units. Loads are connected to sturdy terminal blocks. The **NOVA UACP** is supplied standard in a white powder coat, baked finish for durability. The **NOVA UACP** unit offers ventilation holes for efficient cooling and operation of the charging system.

The **NOVA UACP** has a max capacity of 2000W for 90 min. The **NOVA UACP** utilizes a high performance inverter allowing the units to be loaded to 100% of the rated continuous load capacity.

## ■ dimensions

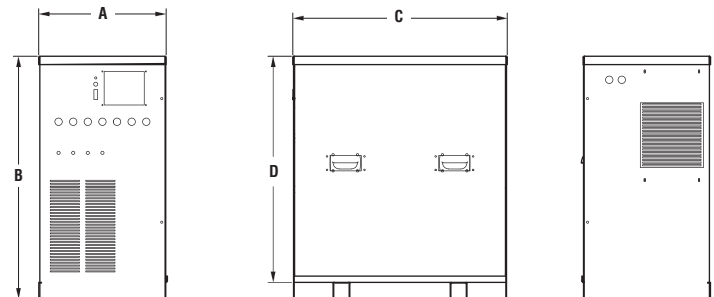

Series	A	B	C	D
NV-UAC-P	15.25" 387 mm	29" 737 mm	25.75" 654 mm	27" 686 mm

## ■ ordering logic

EXAMPLE: NV UAC P 2000W 120V/120V

Series <sup>1</sup>	Operation	Input Power	Options
NVUACP <sup>2</sup>	1500W	120V/120V	AT (autotest)
	2000W <sup>3</sup>	120V/208V	BK (output breaker - specify 2, 3, 4)
		120V/277V	CC (custom color)
		208V/120V	LC (line cord/plug) - not available with TLP
		208V/277V	TB (2 additional terminal blocks - 120V input only)
		277V/120V	TD <sup>4</sup> (time delay)
		277V/208V	TLP (twist lock plug - 120V only) - not available with LC
		277V/277V	WS (twall switch - 120V/120V only)

**NOTE 1:** Freight not included for this item

**NOTE 2:** Not recommended for use with HID lighting

**NOTE 3:** 2000W only available for 120/120V

**NOTE 4:** Autotest (AT) is required when adding time delay (TD)

## ■ specifications: electrical

**BATTERY:** The **NOVA UACP** is designed with a maintenance free, sealed valve regulated lead acid battery that provides a minimum emergency duration of 90 minutes. Recharge time of the battery is twenty-four [24] hours.

**CIRCUIT:** The **NOVA UACP** unit is supplied with a panel which displays input and output rating, load status, charge current and battery voltage. An audible alarm is standard and will make a sound to indicate that the battery voltage is low. In addition, the battery condition and any faults are communicated through the illuminated panel showing the real-time operational data and messages.

## ■ specifications: mechanical

The **NOVA UACP** unit is designed to be floor mounted in indoor installation environments. The units are elevated on supports for flood protection and have anchor holes for secure mounting. The fully enclosed housing top offers added drip protection.

## ■ operation

Using the **NOVA UACP** to convert normally-on lighting into emergency lighting provides greater safety, savings and flexibility. There is the potential for greater illumination on the path of egress with general lighting. By making use of the general lighting you will save the cost of additional emergency lighting battery units and remote heads. Provide a more architecturally pleasing design by eliminating the need of remote heads in the space. With AC power input and output, the installation will be more flexible and there will be no concern of voltage drop to the loads.

The **NOVA UACP** is provided with a field selectable toggle switch for Normally ON or Normally OFF operations. Normally ON operation 120VAC output is provided to the lighting circuit. This is the default setting. Normally OFF operation, the output circuit to the light will only turn on during a power failure.

## ■ pure sine wave

Pure sine wave power is required to ensure there is no interruption in delivering emergency power. The pure sine wave system is compatible with all power supplies, LED drivers and lighting ballasts. The **NOVA UACP** is a standby IPS system with a transfer time of 10 milliseconds, which is suitable for specified lighting loads under emergency backup.

## ■ model rating guide

	Min	Watts
	90	1500
	90	2000

## ■ electrical input rating

Input Rating		
NVUACP 1500W 120V/120V	60Hz	17.0A
NVUACP 1500W 120V/208V	60Hz	17.0A
NVUACP 1500W 120V/277V	60Hz	17.0A
NVUACP 1500W 208V/120V	60Hz	11.0A
NVUACP-1500W-208V/280V	60Hz	11.0A
NVUACP 1500W 208V/277V	60Hz	11.0A
NVUACP 1500W 277V/120V	60Hz	8.0A
NVUACP 1500W 277V/208V	60Hz	8.0A
NVUACP 1500W 277V/277V	60Hz	8.0A
NVUACP 2000W 120V/120V	60Hz	20.0A

## ■ important: LED lighting

The efficiency of external LED power supplies/drivers needs to be considered in all load calculations. Consult factory for more information.

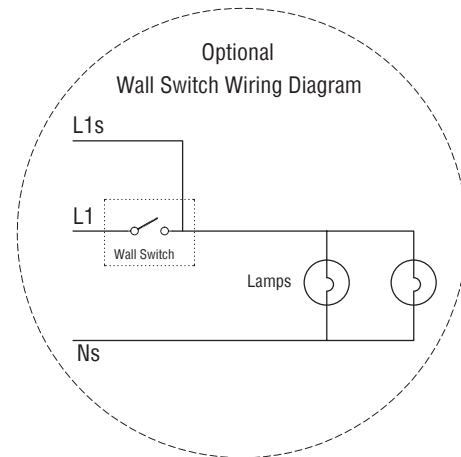

Wall Switch Option (WS): Provides an internal relay which allows two circuits of emergency power to the lights regardless of the wall switch position (on or off).

**NOTE:** Three conductors required to wall switch from inverter's output, see diagram.

# Technical

## ■ autotest

The **NOVA UACP** is constantly monitored by a autotest-diagnostic system. A red, green and orange LED light will indicate utility, battery condition and fault status. The self-diagnostic system monitors the brownout protection, battery overload, battery condition and low voltage disconnect. Before the event of the end of run-time / low voltage disconnect, an audible alarm will sound.

The Beghelli auto-test system automatically performs one 5 minute discharge test monthly and every 6 months it performs two 90 minute discharge tests, 48 hours apart. This tests both full battery capacity and recharge capability. The information is communicated simply and intuitively to maintenance personnel via a single multi-color LED.

## ■ terminal block diagram

Standard with two circuit terminal blocks for output. Consult factory for any additional terminal blocks (4 max).

## ■ warranty

**Unit:** 18 months from ship date, or 12 months from turn-on date; whichever comes first. Additional years can be added. Contact your Beghelli associate for more details.

**Battery:** 1-year full warranty; 9-years pro-rated.

